

Yuedou Pan  
Zhe Wang

# Design of Digital Control System for Electric Drive



冶金工业出版社  
[www.cnmp.com.cn](http://www.cnmp.com.cn)

# 电力拖动数字控制系统设计

(英文版)

潘月斗 王哲 著

北 京

冶 金 工 业 出 版 社

2018

Copyright © 2018 by Metallurgical Industry Press, China  
Published and distributed by  
Metallurgical Industry Press  
39 Songzhuyuan North Alley, Dongcheng District  
Beijing 100009, P. R. China

All rights reserved. No part of this publication may be reproduced, stored in a retrieval system, or transmitted in any form or by any means electronic, mechanical, photocopying, recording or otherwise, without the prior written permission of the copyright owner.

### 图书在版编目(CIP)数据

电力拖动数字控制系统设计=Design of Digital Control  
System for Electric Drive: 英文/潘月斗, 王哲著. —  
北京: 冶金工业出版社, 2018. 3

ISBN 978-7-5024-7643-4

I. ①电… II. ①潘… ②王… III. ①电力传动—  
数字控制系统—系统设计—英文 IV. ①TM921.5

中国版本图书馆 CIP 数据核字 (2018) 第 045325 号

出版人 谭学余

地 址 北京市东城区嵩祝院北巷 39 号 邮编 100009 电话 (010)64027926

网 址 www.cnmp.com.cn 电子信箱 yjcbbs@cnmp.com.cn

责任编辑 宋 良 美术编辑 杨 帆 版式设计 孙跃红

责任校对 李 娜 责任印制 牛晓波

ISBN 978-7-5024-7643-4

冶金工业出版社出版发行; 各地新华书店经销; 三河市双峰印刷装订有限公司印刷  
2018 年 3 月第 1 版, 2018 年 3 月第 1 次印刷

169mm×239mm; 11.75 印张; 228 千字; 178 页

40.00 元

冶金工业出版社 投稿电话 (010)64027932 投稿信箱 tougao@cnmp.com.cn

冶金工业出版社营销中心 电话 (010)64044283 传真 (010)64027893

冶金书店 地址 北京市东四西大街 46 号(100010) 电话 (010)65289081(兼传真)

冶金工业出版社天猫旗舰店 yjgychs.tmall.com

(本书如有印装质量问题, 本社营销中心负责退换)

# **Design of Digital Control System for Electric Drive**

Yuedou Pan

Zhe Wang

Beijing

Metallurgical Industry Press

2018

# Preface

As the computer controlling technology develop rapidly, the superiority and brilliant application prospects are mostly indicated. Current industrial control equipment, robotic systems, and various other electronic control devices have adopted digital control technology. The microprocessor-centric digital controller replaces the traditional analog controller (or analog regulator) contemporarily which is a major technological advancement. Looking back and ahead, it is necessary to carry out the digital control system research, technological development and teaching energetically. Therefore, start from the application, mastering the analysis and design methods of digital control system in the field of automation becomes increasingly important.

This book focuses on production practice. Under the premise of mastering the basic theory of digital control system, it mainly introduces the design method of digital control system of electric drive. This book discusses the design of digital controller in details, as well as introduces the electronic power and some recent advances of digital technology in the field of electronic power.

The first chapter introduces the basic components, the hardware system and software system of the electric drag digital control system. The software system section mainly introduces the overall structure of the software, namely, the main loop program and the interrupt program.

The second chapter introduces the basic features of digital automatic control system of electric drive, help readers to clarify the similarities and differences between the digital system and continuous system, in order to achieve a deep understanding of the digital system.

The third chapter introduces the design and implementation of the digital controller, which is the key of this book. It focuses on digital PID regulator

design and its improved methods, as well as on pole configuration and state estimation of the digital controller designs.

The fourth chapter introduces the essentials and operation steps of digitization of the electric drive automatic control system. Combining with the actual situation, this chapter introduces digital design of the DC double closed-loop speed control system, asynchronous motor vector control system, permanent magnet synchronous motor direct torque control system, AC servo system and etc.

Combining with the engineering practice, the contents cover the digital control system design content and design methods. This book can be used as a reference book for engineering and technical personnel engaged in the design of electric drive control system, or be used as guidance book for undergraduate course design of power electronics and electric power drive, automation specialty and related specialty.

The book was written by Professor Pan Yuedou from University of Science and Technology Beijing. Doctoral Candidate Wang Zhe compiled the section 2.1 in chapter 2. Professor Li Huade made a comprehensive and detailed review of the book. Master Degree Candidates Wang Chengwei, Wang Guofang, and Zhang Lizhong participated in compiling, entering, proofreading the book and etc.

Due to the limitation of time and academic level, there will be unavoidable shortcoming. Readers are welcome to criticize and suggest. The author is sincerely grateful to all of the authors of the references.

Yuedou Pan  
2017. 8

# Contents

<b>Introduction</b> .....	1
<b>Chapter 1 The Constitution of the Electric Drive Digital Control System and Its Hardware and Software System</b> .....	4
1.1 The structure of electrical power drive digital control system .....	4
1.2 The hardware system of the electrical power drive digital control system .....	5
1.2.1 The hardware system of the digital controller .....	6
1.2.2 Signal detector .....	26
1.3 A software system for digital controllers .....	42
1.4 System development and integration .....	43
1.4.1 Requirements for developing a system .....	43
1.4.2 Universal digital development platform .....	44
<b>Chapter 2 The Basic Features of Electric Digital Control System</b> ...	48
2.1 The similarities and differences between the drive digital control system and the electric drive continuous( analog) control system ...	48
2.2 Discretization and sampling .....	49
2.3 Quantification of continuous variables .....	51
2.4 Quantization of incremental encoder pulse signals .....	52
2.4.1 The measurement of rotate speed .....	52
2.4.2 Measurement of angle position .....	55
2.5 Quantization of analog value like voltage and current .....	56
2.5.1 Instantaneous value method .....	56
2.5.2 Average value method .....	57
2.6 Quantization error and proportion factor .....	60
2.6.1 Quantization error .....	60
2.6.2 Scaling factor allocation and overflow protection .....	61
2.7 Data processing and digital filtering .....	62

2. 7. 1	Representation of data .....	62
2. 7. 2	Digital filtering .....	64
<b>Chapter 3</b>	<b>Design of Digital Controller .....</b>	<b>68</b>
3. 1	Design method of digital controller .....	69
3. 1. 1	Approximate design method .....	69
3. 1. 2	Analytic design method .....	70
3. 2	Discretization method .....	70
3. 2. 1	Integral transform method .....	71
3. 2. 2	Zero pole matching method .....	75
3. 2. 3	Equivalent transformation method .....	76
3. 3	PID control .....	78
3. 3. 1	Digital PID regulator .....	78
3. 3. 2	Improvement of digital PID regulator .....	83
3. 3. 3	Open loop feedforward compensation (pre-control) .....	88
3. 4	Design of digital control system based on pole assignment and state estimation .....	89
3. 4. 1	Pole assignment of discrete time state space system .....	90
3. 4. 2	State observer design .....	96
3. 4. 3	Pole configuration of state observer .....	102
3. 4. 4	Pole assignment of discrete system with reference input .....	108
3. 5	Implementation of control algorithm .....	110
3. 5. 1	Implement block diagrams and algorithms .....	110
3. 5. 2	Serial implementation and parallel implementation .....	113
3. 5. 3	Nested program implementation method .....	115
3. 5. 4	Selection of sampling period .....	116
<b>Chapter 4</b>	<b>Full Digital Design of Electric Drive Automatic Control System .....</b>	<b>119</b>
4. 1	Digital control system design content and steps .....	119
4. 2	The overall program determination of electric drive automatic control system digital design .....	122
4. 3	Selection of microprocessor chip .....	123
4. 4	Software design of digital control system .....	125
4. 4. 1	The basic method of software design .....	125

---

4.4.2	Specific issues of software design of computer control system	126
4.4.3	Software anti-jamming measures of digital control system	126
4.4.4	Time monitor	127
4.4.5	Reliability of input/output software	128
4.5	All-digital design of DC double closed-loop speed control system	128
4.5.1	Hardware structure design of digital DC speed control system	130
4.5.2	Software design of digital DC speed control system	133
4.5.3	Digital filter design	135
4.5.4	The design of digital current regulator	136
4.5.5	The design of digital speed regulator	136
4.5.6	Self-optimizing control of digital PID parameters	140
4.5.7	Fault self-diagnosis and protection function of digital control system	144
4.6	Digital design of vector control system for asynchronous motor	145
4.6.1	Hardware composition of digital induction motor vector control system based on DSP	146
4.6.2	Software design (arithmetic program and control algorithm)	148
4.7	Digital design of direct torque control system for permanent magnet synchronous motor	158
4.7.1	Hardware system of digital direct torque control system of permanent magnet synchronous motor based on DSP	158
4.7.2	Software design	162
4.8	Digital design of AC servo system	164
4.8.1	Design of AC servo system as the core of DSP	164
4.8.2	The AC servo system hardware design with DSP as the core	165
4.8.3	Design of digital controller for AC servo system with DSP as the Core	170
4.8.4	The AC servo system programming with DSP as the core	174
	<b>References</b>	178

# Introduction

Electric drive analog simulation control bases on analog control devices. In this type of control system, the collection of all control variables (sampling), the information exchange between the functional blocks, as well as the calculation, control, output and other functions of these blocks are continuous and parallel, therefore, this system is also known as continuous control system. The electric drag digital control system, which corresponds to the electric analogy control system, is based on digital control devices. The core of the electric drag digital control system is the microprocessor (computer) and in such control system, a microprocessor is supposed to complete a large number of tasks. For the reason that in a certain period of time, the microprocessor can only deal with one task, thus these tasks must be applied in time-sharing and serial execution mode, therefore the continuous control variable has been intermitted into control variable which repeats on a timed interval, that's the discrete control.

As a discrete time system, the electric drive digital control system can be described by differential equations, and one can use z-transform and discrete state space method to analyze and design digital control system. Digital control system design methods are usually continuous discretization design method (or analog design method), discrete field direct design, discrete state space design (such as least energy control, discrete quadratic optimal control), complex control system (cascade control, feedforward control, pure hysteresis compensation control, and multivariable decoupling control) and so on.

The principles or the performances of the two types of control systems are basically the same. They are characterized by stability, controllability, observability, dynamic characteristics, and their performance are measured by the stable margin, steady-state indicators, dynamic indicators and comprehensive indicators. The "digital control of the electric drive automatic control system" is also known as "computer-controlled power drag automatic control system". So far, in a variety of applications, continuous (analog) control of the AC and DC speed control system, as well as position the automatic control system has been replaced by digital control. The successful application of digital control technology (computer control technology) in the field of electric power drag is a major scientific and technological progress in modern times.

The advantages of electric driving digital automatic control system are as below :

(1) The computer-controlled power electronic conversion controlled by a computer enable the motor having an ideal power supply, which guarantee the improving of the performance of the system, and extending the functions of the system.

(2) The microprocessor based control device can perform high-precision calculation, transformation and control, including complex calculations and judgments. The modular structure of the software can add, change and delete the application in real time, and can be updated completely when the actual system changes. The flexibility of the software control greatly enhances the controller's ability to adapt to the controlled object, thus the control strategy and the control method are realized.

(3) The hardware of digital control system has high degree of standardization, low production cost and is unaffected by the device temperature drift.

(4) The digital control device has a small volume, a light weight, and low energy consumption.

(5) The system has a strong communication function, it can be connected with the industrial control system host computer work through the field bus.

(6) The system is able to monitor the system running status, provide early warning, trouble shooting and data acquisition.

The disadvantages of digital control of the electric drive automatic control system are as below :

(1) There exist sampling and quantization errors. The number of digital-to-analog (D-A), modulo (A-D) converters and the word length of the computer are constant. Increasing the number and word length, or increasing the sampling frequency can reduce this error, but none of these variables can be increased indefinitely.

(2) The dynamic response is slower than that of electric drive automatic control continuous (analog) system. Since the computer deals with the signal in a serial manner, the task will always take a while before it is complete. Therefore, the current solution is to improve the speed of the microprocessor.

(3) The sampling time delay may cause instability of system.

(4) The software to achieve the function is difficult to observe directly by instrument (such as oscilloscope, multimeter, ammeter, voltmeter, etc.).

New progress in digitization of control systems:

With the rapid development of computer technology and the growing popularity of the application, after the 1970s, computers have found an increasingly wide utilization in the field of automatic with the advent of microprocessors. Most controlling systems are

controlled by computers nowadays. These control system includes industrial real-time control system, servo mechanical control system of various electronic devices and even control system of military facilities or control system of aerospace equipment. In particular, the reliability of industrial computer control technology, after the use of redundant hardware and software self-diagnosis and other measures has been greatly improved, the automation control of industrial production has entered the area of computer.

In the 21st century, the computer control technology is developed in the direction of miniaturization, intellectualization, networked and standardization.

\* Miniaturization indicates that the embedded computer has penetrated into the front and bottom of the control, such as a variety of sensors, actuators, process channels, interactive devices, communications equipment, however Micro-smart sensors, actuators and controllers made up of the micro-electromechanical system (micro elector mechanical system) will enable the control technology to enter new areas.

\* Intellectualization indicates that the control process has its adaptive, self-learning, self-diagnosis and self-repair function, which leads to further improvement of control quality.

\* Networked indicates the structure of the control system, which is from the information processing unit to the system of information transmission. The use of high reliability, low cost and integrated fieldbus, Ethernet technology and Internet technology, the control system continues to expand the scale of production to control the whole factory, as well as the cross-region public traffic.

\* Standardization indicates that a series of standards to regulate the hardware and software systems of the control system. The interchangeability of equipment and the connectivity of the system make the system more flexible, for example, various sizes of programming controller (PLC), open configuration software and development platform for the construction of a variety of control systems brings convenience, which greatly improves the system development efficiency and reduce the system maintenance costs.

# Chapter 1 The Constitution of the Electric Drive Digital Control System and Its Hardware and Software System

## 1.1 The structure of electrical power drive digital control system

Figure 1-1 shows the constitution of the continuous (analog) electric power automatic control system.

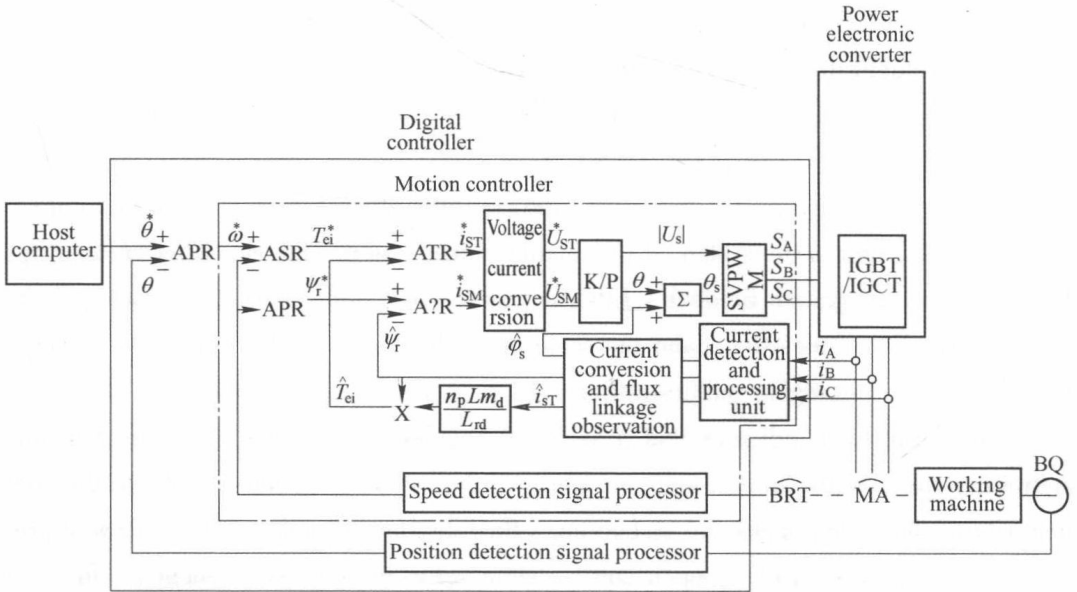

Figure 1-1 Block diagram of automatic control system of continuous electric drive

Due to some features of the constitution of the digital electric drive automatic control system, the physical meaning is clear and the principle is easy to understand. Thus, the design of the digital electric drive automatic control system is always in accordance with the continuous control system before entering into the progress of digitalizing. The basic structure of the electrical drive automatic control system after digital design is shown in Figure 1-2.

Digital control system basically consists of the computer structure of the digital processing system, peripherals, input and output channels and so on. As shown in Figure

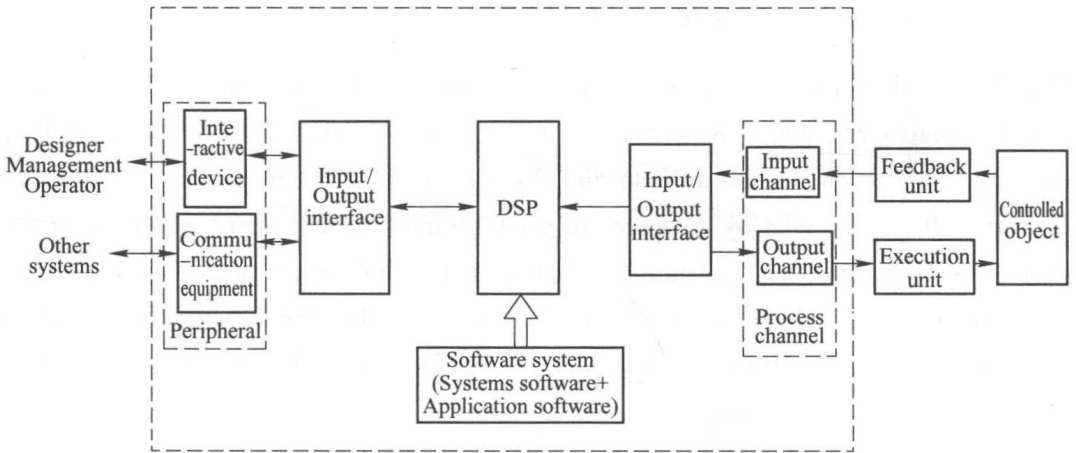

Figure 1-2 Block diagram of digital control system for electric drive

1-2, the hardware of the digital control system generally includes the host, the input and output channels, the peripherals and etc. The host, which includes the CPU, storage devices, bus and so on, is the core of the system. The host sends various commands to the various parts of the system by operating the software program, in order to detect or control the object. Input and output channels are the bridges for information exchange between the host system and the object. The input channel converts the controlled parameters of the object into digital signals that can be received by the system. The output channel converts the control instructions and data output from the system into signals that control the object. Peripherals are the devices for the information exchange with outsiders, generally include man-machine interface, input and output device and external storage devices.

Besides, hardware system digital control system includes corresponding software system. Software is a program that can perform various functions. The software usually includes system software, application software and database and etc. System software includes operating systems, diagnostic systems and development systems. Application software includes various algorithms for users. The database is a software for archiving and managing data.

## 1.2 The hardware system of the electrical power drive digital control system

Digital electric drive automatic control system consists of generalized control object (power electronic converter and motor), signal detector and digital controller and so on.

### 1.2.1 The hardware system of the digital controller

Digital controller consists of the sampling holder, A-D converter, microprocessor (digital computer), and D-A converter, etc. Continuous signals are typically sampled, quantized, and encoded into discrete digital signals  $e(kT)$  in time and size by the A-D converter. It is processed by computer to get the digital control signal  $u(kT)$ . Then it passes the D-A converter to restore the digital quantity into continuous control signal  $u(t)$ . Finally, the  $u(t)$  control the object. Among them, the digital controller consists of microprocessor, A-D converter and D-A converter. The control law of the digital controller is achieved by the computer program.

#### 1.2.1.1 Microprocessor

Microprocessor is the core of the digital system. The choice of models often directly affects the control function of the system and the realization of the control effect. Basically, there exist various microprocessors for digital control system, and their performances and structures are different. Therefore, choosing the best control core is a serious task for professional engineering and technical experts. Thus, one must have a comprehensive understanding of various microprocessors.

##### A MCU

Single Chip Microcomputer is obviated as MCU. All things like the central processing unit (CPU), POM, RAM, I/O interface, programmable timer/counter, are integrated in a chip. Some MCU also contain A-D converters. After the US Fairchild company produce the first MCU in 1974, a large number of MCU have been produced in decades. International Companies like Intel, Motorola, Zilog, TI, NEC, have launched their own MCU series.

Its characteristics are;

- (1) High integration and powerful.
- (2) Reasonable structure, strong storage capacity, fast.
- (3) Strong Anti-interference ability.
- (4) Abundant instructions.

Its performance index:

(1) Whether the CPU instruction sets are abundant? The assembler consisting of instruction mnemonics is converted from a compiler to a data file that can be recognized by the microcontroller. And then it is executed sequentially by the microcontroller. Assembly language instructions can generally be sorted into the following groups: Arith-

metric operations, logical operations, data transferring, program branching.

(2) Whether the speed is fast. The speed is the system clock frequency and the length of the instruction execution cycle.

(3) Whether the resources are rich. The resources include RAM (SRAM, DRAM), ROM (EPROM, PROM, EEPROM), I/O interface, A-D and D-A conversion, interrupt and so on. The function of ROM is to store programs and constants. The function of RAM is to store variables and intermediate results.

(4) Power consumption and volume.

The following describes the varieties and main features of high-performance MCU.

- MCS-51 series

The MCS-51 series of microcontrollers is a high-performance 8-bit microcontroller made by Intel, it is based on the MCS-48 family of microcontrollers, as shown in Figure 1-3.

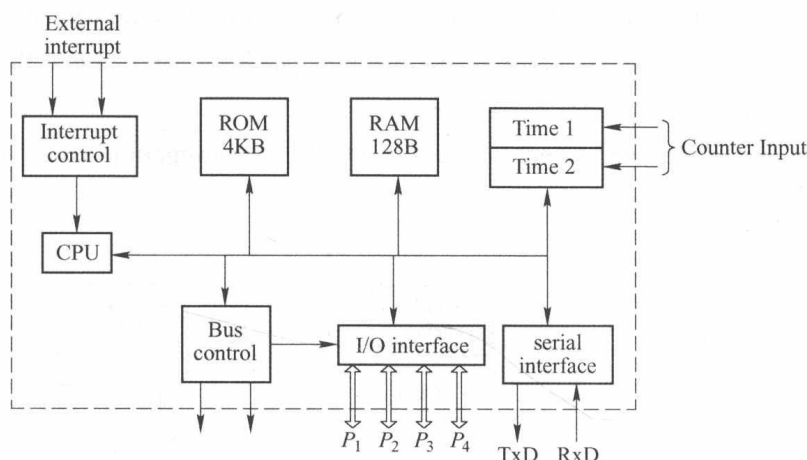

Figure 1-3 MCS-51 block diagram

Basic type: 8031、8051、8751、HMOS (High Density Metal Oxide Semiconductor) process, MCU 8031 without ROM, MCU 8051 with solidified 4KB ROM, MCU 8751 with 4KB EPROM.

Derived types: 8032、8052、8752. They add ROM and RAM capacity, timers, and interrupt sources on the basic types.

Low-power and high-speed types: 80C31、80C52、87C52. They use the HCMOS (High Density Complementary Metal Oxide Semiconductor) process.

High performance types: 80C52、83C252、87C252. It uses CHMOS (hybrid complementary metal oxide semiconductor) process, integrated HSI/HSO (high-speed input/high-speed output), PWM port based on the derived types.

Main feature:

(1) Hardware function: 4 ~ 8KB Internal ROM, 128 ~ 256B RAM, External addressing range is 64KB, 5 interrupt sources, two 16-bit timers/counters. 32 I/O interfaces.

(2) Software function: Rich instruction set, Internal bit processor, suitable for logical processing and control.

(3) The external crystal oscillation frequency is 6 ~ 12MHz, and the instruction cycle is 1μs.

• MCS-96 series

The MCS-96 series (shown in Figure 1-4) is one of the highest performance single-chip series and is suitable for high-speed, high-precision work control. It was produced by Intel Company in 1983. The main features of its typical products are as follows:

(1) 16-bit CPU: It has a register-register structure instead of the previous accumulator structure. The CPU can operate directly on this structure to eliminate the bottleneck caused by the accumulator, in order to improve the speed of operation and the capability of data throughput.

(2) Efficient instruction system: 32 bits (double word) operation.

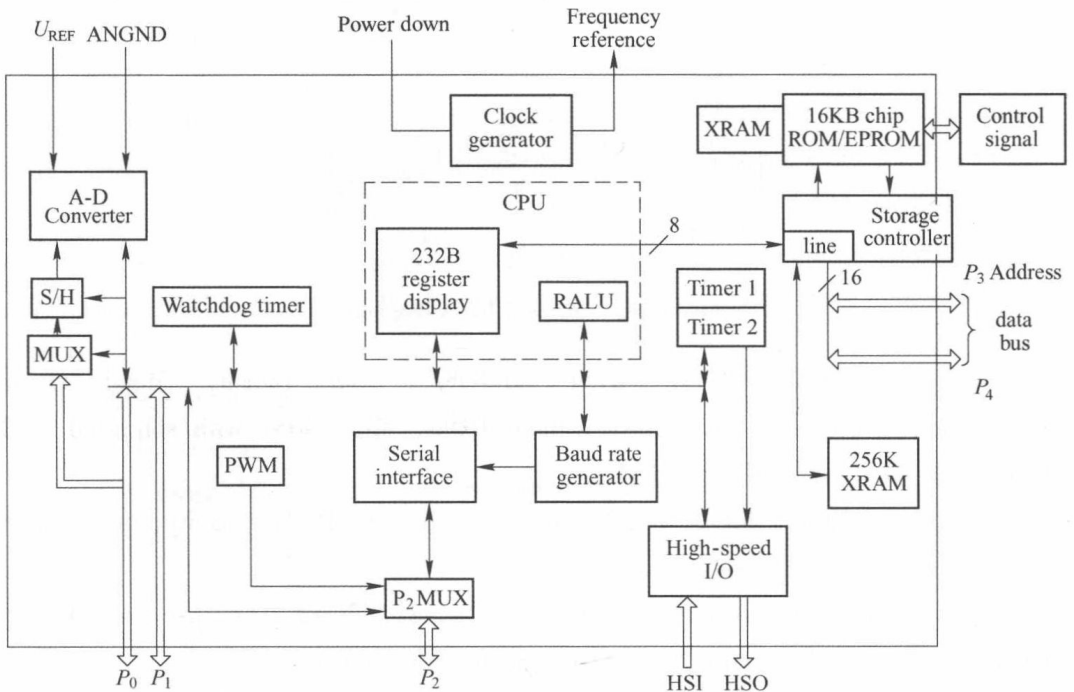

Figure 1-4 MCS-96 block diagram