

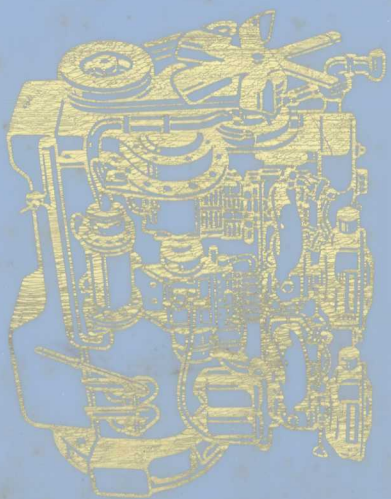

# 柴油机零件图册

PARTS CATALOGUE FOR DIESEL ENGINE MODEL 6120



中华人民共和国

THE PEOPLE'S REPUBLIC OF CHINA

杭州汽车发动机厂

HANGCHOW AUTOMOBILE ENGINE WORKS

Tk 42-64  
2



# 柴油機零件圖冊

PARTS CATALOGUE FOR DIESEL ENGINE MODEL 6120

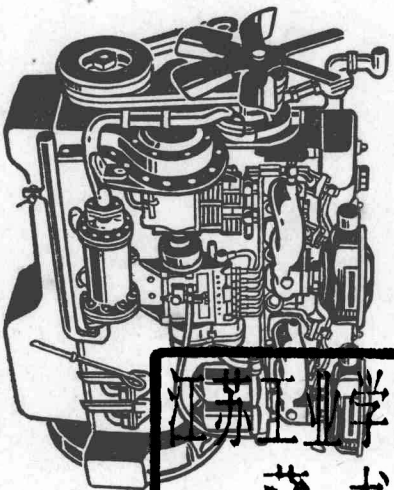

江苏工业学院图书馆  
藏书章

中华人民共和国  
THE PEOPLE'S REPUBLIC OF CHINA

杭州汽车发动机厂  
HANGCHOW AUTOMOBILE ENGINE WORKS

# 毛主席语录

我们中华民族有同自己的敌人血战到底的气概，有在自力更生的基础上光复旧物的决心，有立足于世界民族之林的能力。

《论反对日本帝国主义的策略》

QUOTATION FROM

CHAIRMAN MAO TSETUNG

**We the Chinese nation have the spirit to fight the enemy to the last drop of our blood, the determination to recover our lost territory by our own efforts, and the ability to stand on our own feet in the family of nations.**

“On Tactics Against Japanese Imperialism” (December 27, 1935),  
Selected Works, Vol.1, p.170.

# 前 言

伟大领袖毛主席教导我们：“革命就是解放生产力，革命就是促进生产力的发展。”无产阶级文化大革命以极其雄伟的力量，推动着我国社会主义建设迅速发展。在党的“九大”团结胜利的精神鼓舞下，在毛主席的无产阶级革命路线指引下，我厂广大革命职工，高举“鞍钢宪法”伟大红旗，狠批了叛徒、内奸、工贼刘少奇的“专家治厂”、“洋奴哲学”、“爬行主义”等反革命修正主义黑货。在伟大领袖毛主席的“独立自主、自力更生”的伟大方针指引下，发扬敢想、敢干、敢于创造的无产阶级革命精神。在兄弟单位的大力支持下，试制成功6120柴油机以及功率更高的6130柴油机。这是一种具有我国独特风格，新型先进的柴油发动机，它重量轻，马力和大，振动小，结构简单牢固，操纵维修方便，并且可以使用多种燃料。大宜作为汽车、船舶、电站以及工程机械的动力，用途广泛。这一新成果的出现，雄辩地证明了毛主席“精神变物质”的伟大真理，充分显示了用战无不胜的毛泽东思想武装起来的我国工人阶级、革命干部和革命技术人员具有无穷的智慧和无限的创造力。

遵照伟大领袖毛主席“备战、备荒、为人民”和“中国应当对于人类有较大的贡献”的教导，为适应生产和使用管理的需要，现以我厂生产的6120型柴油机（基本型）为主要叙述对象，编成零件图册，对于各种变型及配套，除按各该机型专用零部件外，其他零部件均与基本型通用。

订购6120柴油机零部件时，必须提供下列说明：

- 1, 柴油机的出厂年份与编号；
- 2, 自本图册中查出所订零部件号；
- 3, 所订零部件名称；
- 4, 所订零部件属于那一部份组件的名称，如气缸体总成，喷油泵总成等。

一般易损零件，标准件及非金属制品的各种垫片可直接到当地机械配件供应部门采购。

遵照伟大领袖毛主席“中国人民有志气，有能力，一定要在不远的将来，赶上和超过世界先进水平”的教导，随着我国社会主义建设事业飞跃发展的需要，本产品将不断地改进和发展，故本零件图册过一定时期将进行补充和修订，希用户注意。

中国 杭州 杭州汽车发动机厂

1 9 7 0

## Foreword

Our great leader Chairman Mao teaches us: "Revolution means liberating the productive forces and promoting their growth." The Great Proletarian Cultural Revolution, with its tremendous momentum, has pushed forward the socialist construction of our country and made it develop rapidly. Encouraged by the spirit of unity and victory incarnated in the Ninth National Congress of the Chinese Communist Party and guided by the revolutionary line of Chairman Mao, we, all the workers, revolutionary cadres and technicians of our works, holding aloft the great red banner of the Constitution of the Anshan Iron and Steel Company, have severely criticized the fallacy of relying on experts to run the factory, the philosophy of slavish compradors, the doctrine of trailing behind at a snail's pace — the counter-revolutionary revisionist trash peddled by the renegade, hidden traitor and scab Liu Shao-chi. Under the great orientation of independence and self-reliance put forward by our great leader Chairman Mao, we have promoted the spirit of the proletariat, by virtue of which we dare to think, dare to do, and dare to create. Now, with the great support of our brotherly units, we have successfully designed and produced 6120 Diesel engine and 6130 Diesel engine — one of higher output. This is a special kind of engine, new and advanced in design, with peculiarities fully showing the ability of our working class: the engine being of light weight, the output high, the vibration slight, the structure compact and rigid, its control and maintenance convenient. Besides, for an engine of this kind, multi-fuel can be used. It can provide a prime mover for cars, ships, power stations and machinery of various sorts. In a word, it has found a wide use. The appearance of this new product eloquently testifies the great truth of Chairman Mao's assertion: "Consciousness can be transformed into matter", fully displaying the inexhaustible wisdom and the boundless creativeness of the workers, revolutionary cadres and technicians in our country, who are armed with invincible Mao Tsetung Thought. According to our great leader Chairman Mao's teachings: "Be prepared against war, be prepared against natural disasters, and do everything for the people", and "China ought to have made greater contributions to mankind", we have published this catalogue, in which the parts and members of 6120 Diesel engine (general type)

are described — a catalogue intended to satisfy the requirements in the use of the engine. The descriptions are also applicable to the parts and members of modified-type engines, but not to those especially made for them.

The following remarks are given for the consideration of our customers, who desire to give an order for 6120 Diesel engine spare parts:

1. Date of delivery of the engine and its serial number.
2. Serial numbers of the parts as indicated in the catalogue.
3. Names of the parts required.
4. Name of the assembly of which the parts required are components, e.g., the cylinder block assembly, the fuel injection pump assembly etc.

All fragile parts, standardized parts, and non-metal gaskets are available at the supply offices of machine parts.

In accordance with our great leader Chairman Mao's teaching: "The Chinese people have high aspirations, they have ability, and they will certainly catch up with and surpass advanced world levels in the not too distant future" and in line with the rapid development of the socialist construction in our country, we shall continually improve the design and characteristics of the engine above mentioned, thereby, resolving, in a certain period, to revise and supplement the catalogue we have issued. Of this, we hope, our customers will take notice.

Hangchow Automobile Engine Works  
Hangchow, China  
1970

6120 柴油机外形图

GENERAL VIEW OF 6120 DIESEL ENGINE

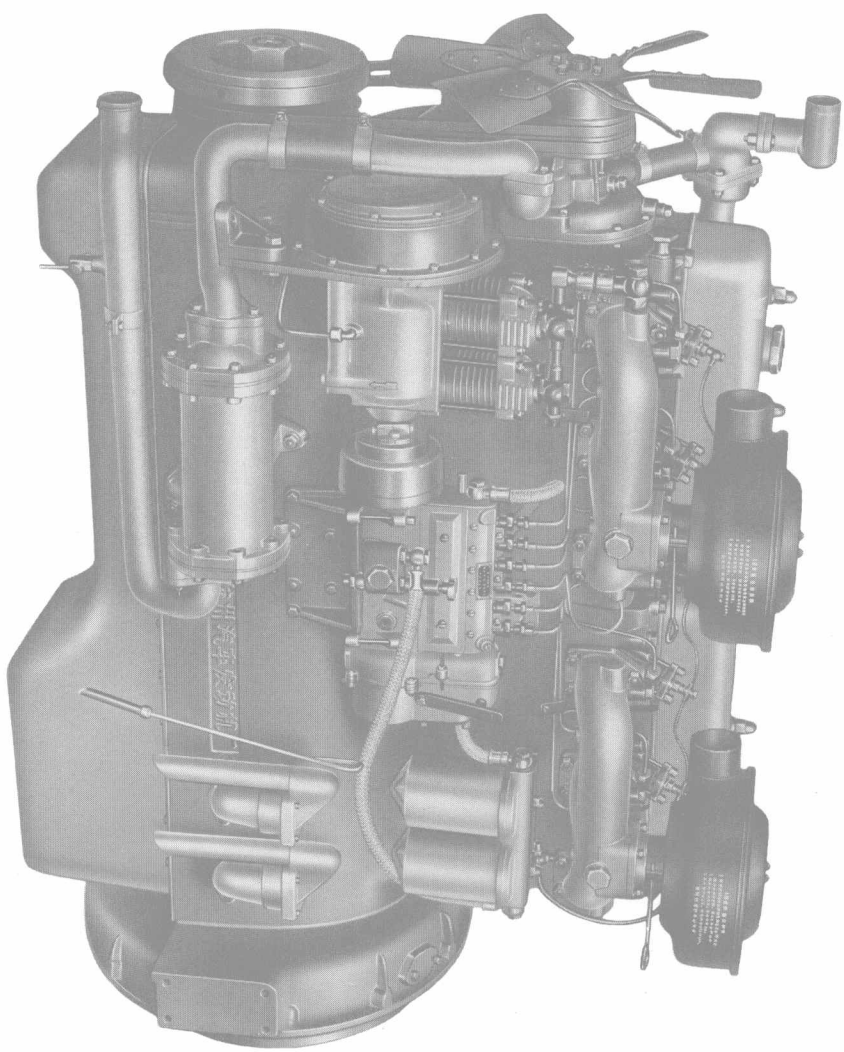



# 目 录

## Contents

1. 气缸体总成 Cylinder Block	1	10. 双级空气滤清器总成 Double Stage Air Cleaner	39
2. 气缸盖总成 Cylinder Head	7	11. 滑油管总成 Oil Piping	43
3. 活塞与连杆 Piston and Connecting Rod	11	12. 滑油管总成 (6120Q-1) Oil Piping	47
4. 曲轴与飞轮 Crankshaft and Flywheel	15	13. 滑油泵总成 Lubricating Oil Pump	51
5. 传动机构 Gear Train System	19	14. 滑油粗滤器总成 Lubricating Oil Coarse Filter	55
6. 凸轮轴总成 Camshaft	23	15. 滑油精滤器总成 Lubricating Oil Fine Filter	59
7. 配气机构 Valve-Actuating Mechanism	27	16. 滑油冷却器总成 Oil Cooler	63
8. 油底壳总成 Oil Sump	31	17. 冷却水管总成 Cooling Water Piping System	67
9. 进、排气管总成 Intake Manifold and Exhaust Manifold	35	18. 冷却水泵总成 Cooling Water Pump	71

19. 柴油管总成 . . . . .	75	27. 调速器总成 . . . . .	111
Fuel Oil Piping		Governor	
20. 柴油滤清器总成 . . . . .	79	28. 喷油角度提前器总成 . . . . .	117
Fuel Oil Filter		Injection-Advance Device	
21. 喷油泵总成 ( B 16M R85 F Z—1 ) . . . . .	83	29. 喷油器总成 . . . . .	121
Fuel Injection Pump		Fuel Injector	
22. 输油泵总成 . . . . .	89	30. 起动机机构 . . . . .	125
Fuel Supply Pump		Starting System	
23. 调速器总成 . . . . .	93	31. 起动液喷射器总成 . . . . .	129
Governor		Starting-Fuel Injector	
24. 喷油角度提前器总成 . . . . .	97	32. 空气压缩机总成 . . . . .	133
Injection-Advance Device		Air Compressor	
25. 喷油泵总成 ( B Z6J 85×8S O4 ) . . . . .	101	33. 废气涡轮增压器总成 . . . . .	139
Fuel Injection Pump		Exhaust Turbine Supercharger	
26. 输油泵总成 . . . . .	107	34. 专用工具 . . . . .	143
Fuel Supply Pump		Special Tools	

气 缸 体 总 成  
CYLINDER BLOCK

6120—1002

1. 气缸体总成 CYLINDER BLOCK

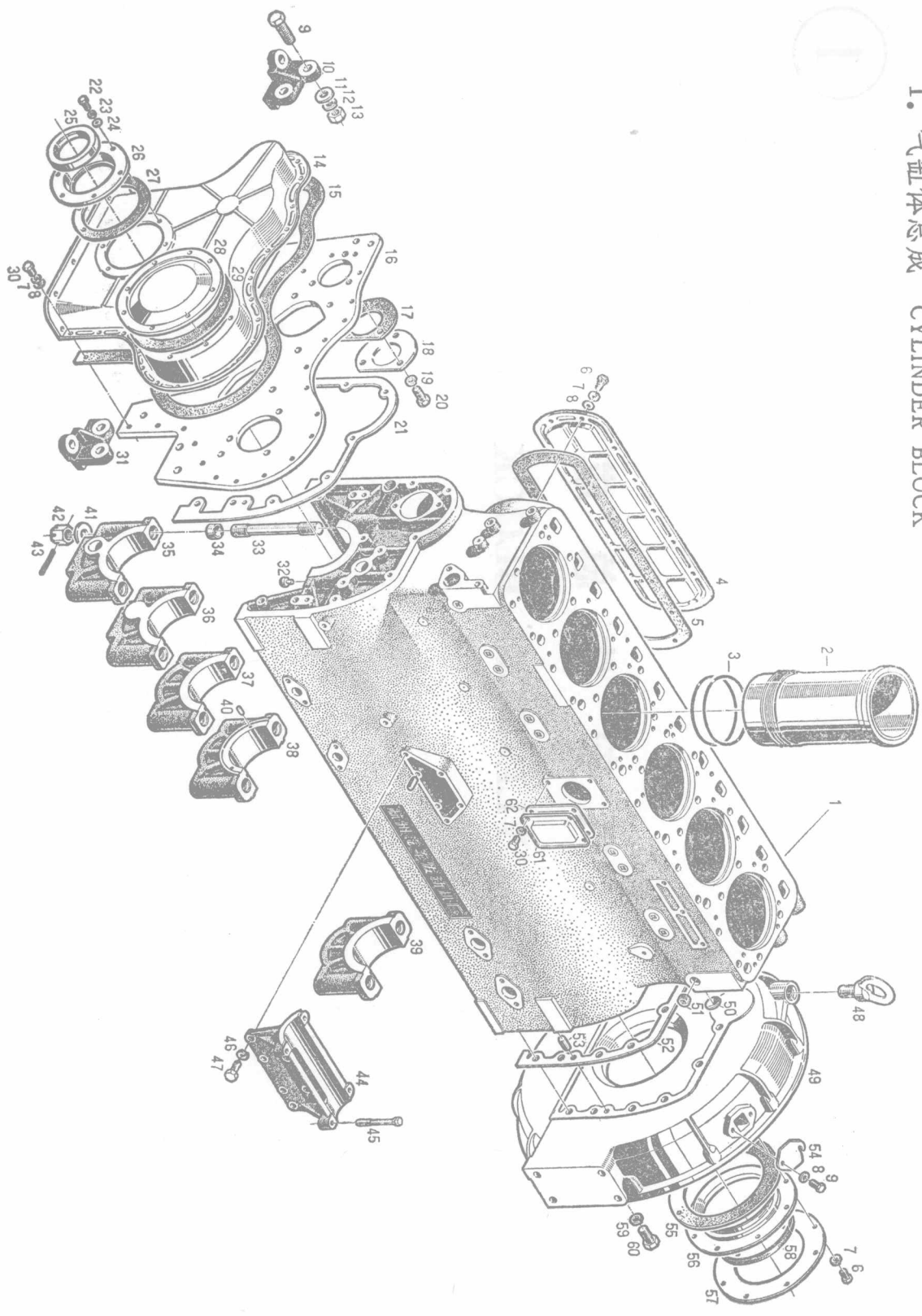

# 1. 气缸体总成 CYLINDER BLOCK

标号 Item	件号 Part No.	名称	Description	数量 Qty
1	6120—1002—011	气缸体	Cylinder block	1
	6130—1002—011	气缸体	Cylinder block	1
2	6120—1002—012	气缸套	Cylinder liner	6
	6130—1002—012	气缸套	Cylinder liner	6
3	6120—1002—013	封水圈	Cylinder liner packing ring	12
	6130—1002—013	封水圈	Cylinder liner packing ring	12
4	6120—1002—018	推杆室盖	Valve tappet chamber cover	2
	6120—1002—019	软木垫片	Cork gasket	2
5	6120—1002—019	软木垫片	Cork gasket	2
6	GB21—58	螺栓 M 8 × 20	Bolt M 8 × 20	38
7	GB93—58	弹簧垫圈 10	Lock washer 10	64
8	GB95—58	垫圈 8	Washer 8	54
9	GB21—58	螺栓 M16 × 50	Bolt M16 × 50	4
10	6120—1002—021	发动机右支架	Right engine mounting bracket	1
11	GB95—58	垫圈 16	Washer 16	4
12	GB93—58	弹簧垫圈 16	Lock washer 16	4
13	GB52—58	螺母 AM16	Nut AM16	4
14	6120—1002—004	正时齿轮室盖	Timing gear cover	1
15	6120—1002—037	软木垫片	Cork gasket	1
16	6120—1002—016	气缸体前端板	Cylinder block front cover	1
17	6120—1002—046	软木垫片	Cork gasket	1
18	6120—1002—045	备用泵盖	Auxiliary pump cover	1
19	GB93—58	弹簧垫圈 12	Lock washer 12	7
20	GB21—58	螺栓 M12 × 14	Bolt M12 × 14	3

标号 Item	件号 Part No.	名称	Description	数量 Qty
21	6120—1002—017	钢纸垫片	Fiber gasket	1
22	GB30—58	螺栓 M6×14	Bolt M 6 × 14	14
23	GB93—58	弹簧垫圈 6	Lock washer 6	14
24	GB95—58	垫圈 6	Washer 6	14
25	6120—1005—013	曲轴前油封	Crankshaft front oil seal	1
26	6120—1002—006	前油封座	Front oil seal seat	1
27	6120—1002—041	软木垫片	Cork gasket	1
28	6120—1002—005	传动齿轮盖板	Drive gear cover	1
29	6120—1002—039	软木垫片	Cork gasket	1
30	GB21—58	螺栓 M8×14	Bolt M 8 × 14	28
31	6120—1002—023	发动机左支架	Left engine mounting bracket	1
32	6120—1002—030	滑油道堵塞	Oil gallery plug	4
33	6120—1005—042	主轴承螺栓	Main bearing bolt	14
34	6120—1005—022	主轴承定位套	Main bearing cap dowel bush	14
35	6120—1005—045	第一道主轴承盖	1 st main bearing cap	1
36	6120—1005—068	第二道主轴承盖	2 nd main bearing cap	1
37	6120—1005—048	第三、五、六道主轴承盖	3 rd 5 th and 6 th main bearing cap	3
38	6120—1005—044	第四道主轴承盖	4 th main bearing cap	1
39	6120—1005—040	第七道主轴承盖	7 th main bearing cap	1
40	6120—1005—039	止推片定位肖	Thrust plate dowel pin	4
41	GB97—58	垫圈 20×4	Washer 20 × 4	14
42	6120—1005—043	主轴承螺母	Main bearing nut	14
43	GB91—58	开口肖 4×40	Cotter pin 4 × 40	14

标号 Item	件号 Part No.	名称	Description	数量 Qty
44	6120—1002—027	喷油泵支架	Fuel injection pump bracket	1
45	6120—1002—031	喷油泵固定螺钉	Fuel injection pump locating bolt	4
46	GB93—58	弹簧垫圈 10	Lock washer 10	9
47	GB21—58	螺栓 M10×30	Bolt m10×30	9
48	6120—1002—029	发动机吊环	Shouldered eye bolt	1
49	6120—1002—014	飞轮壳	Flywheel housing	1
50	C44032	塞片	Shim	1
51	C61302	方孔锥形螺塞	Socket head plug	4
52	6120—1002—015	钢纸垫片	Fiber gasket	1
53	GB119—66	园柱肖10d <sub>4</sub> ×25	Straight pin 10d <sub>4</sub> ×25	6
54	6120—1002—024	正时检查孔盖	Timing inspection window cover	1
55	6120—1005—067	软木垫片	Cork gasket	1
56	6120—1005—036	后油封座	Rear oil seal seat	1
57	6120—1005—035	后油封盖	Rear oil seal cover	1
58	6120—1005—026	橡胶石棉油封	Rubber-asbestos oil seal	1
59	GB93—58	弹簧垫圈 14	Lock washer 14	10
60	GB21—58	螺栓 M14×50	Bolt M14×50	10
61	6120—1002—025	水套盖	Water jacket cover	1
62	6120—1002—026	垫片	Gasket	1

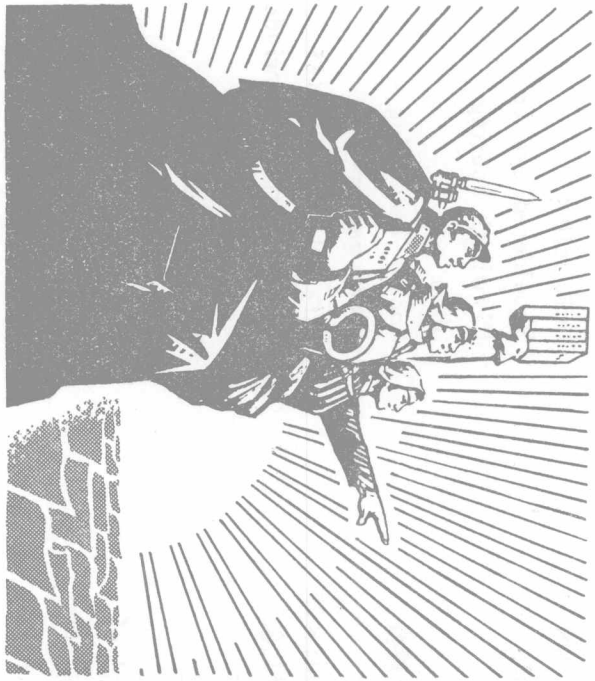

MAN IN THE SUIT



2

气 缸 盖 总 成  
CYLINDER HEAD

6120—1003