

普通高等教育“十二五”规划教材



# 机械原理

( 英汉双语 )

张春林 张颖 主编



 机械工业出版社  
CHINA MACHINE PRESS



Theory of Machines and Mechanisms  
(Bilingual Edition)

# 机械原理

(英汉双语)

主编 张春林 张颖

参编 赵自强 李志香 马超

冯欣欣 王泽洋



机械工业出版社

本书是按照高等工科教育逐步与国际教育接轨的要求编写的《机械原理》英汉双语教材。在满足国内教学基本要求的基础上,体现了我国机械原理的教学现状和特色,吸取了国外同类教材的特点。全书内容从机构分析、机构设计、机构系统设计到机械动力学,遵循以设计为主线,加强基本概念、基本理论、基本方法,理论与工程实践相结合的指导思想,对传统机械原理的内容进行了整合,结合现代科学技术的发展,增加了新内容,删减了过于陈旧的内容。

全书共有13章。第1章介绍机械的基本概念;第2章到第4章,主要介绍机构结构分析、机构受力分析和机构运动分析;第5章到第9章,主要介绍常用机构的设计;第10章介绍空间机构和机器人机构;第11章介绍机构系统的设计;第12章和第13章主要介绍飞轮设计和平衡设计。创新设计的思想融于各章内容中。

本书的英文内容,在反映中文内容的前提下,采用典型的科技英语表现方式和通俗易懂的词汇,简便易读。

本书可作为高等工科大学机械类专业的机械原理教材,特别适合作为英汉双语教材,也可以作为机械工程人员的参考用书。

#### 图书在版编目(CIP)数据

机械原理(英汉双语)/张春林,张颖主编. —北京:机械工业出版社, 2012.3

普通高等教育“十二五”规划教材  
ISBN 978-7-111-36091-9

I. ①机… II. ①张…②张… III. ①机构学—双语教学—高等学校—教材 IV. ①TH111

中国版本图书馆CIP数据核字(2011)第207537号

机械工业出版社(北京市百万庄大街22号 邮政编码100037)

策划编辑:邓海平 余 皞 责任编辑:余 皞 王晓艳

版式设计:霍永明 责任校对:樊钟英

封面设计:张 静 责任印制:杨 曦

保定市中国画美凯印刷有限公司印刷

2012年2月第1版第1次印刷

184mm×260mm·23.5印张·594千字

标准书号:ISBN 978-7-111-36091-9

定价:49.80元

凡购本书,如有缺页、倒页、脱页,由本社发行部调换

电话服务

网络服务

社服务中心:(010)88361066 门户网:<http://www.cmpbook.com>

销售一部:(010)68326294

教材网:<http://www.cmpedu.com>

销售二部:(010)88379649

读者购书热线:(010)88379203 封面无防伪标均为盗版

## Preface

Along with the rapid development of science and technology, the higher education will speed up internationalization. So it is necessary to compile a compatible textbook which not only has Chinese feature, but also makes for globalization. This is a new object that the teaching reform of China's higher education is faced with. On the one hand, the direct adoption of the foreign classical textbooks does not suit the actual state of our teaching in Chinese universities; on the other hand, the Chinese language textbooks cannot be brought in the line with the international practice. Therefore, we will compile a bilingual textbook on "theory of machines and mechanisms" with the support of China Machine Press.

This book is based on the basic teaching requirement of the "theory of machines and mechanisms" issued by the Ministry of Education. The basic concepts, basic principles and basic skills are reinforced, and we take the content of synthesis or design as a main clue to cultivate consciousness and capability of innovation for mechanical engineering. We hope that this book can include the features inheriting from the traditional textbooks, and can be in line with some foreign textbooks.

1. Descriptions about "theory of machines and mechanisms" in the Chinese book

1) This book is compiled with analysis of mechanisms, design of mechanisms, design of mechanism systems and dynamics of mechanisms.

2) It highlights the analytical methods, such as kinematic analysis of mechanisms, force analysis of mechanisms, synthesis of mechanisms, cam mechanisms and balancing design, etc., and de-emphasizes graphical methods.

3) Some of the traditional contents of "theory of machines and mechanisms" are modified, integrated and expanded in this book.

The concepts of mechanisms and machines are defined in Chapter 1, and they are up-to-date ideas. Composition principle of mechanisms is expanded to creative design of mechanisms. A new method which is used to determine the self-locking of a mechanism has been brought up, in which we will use the total reaction force acting on the friction cone or friction circle to determine self-locking phenomenon of a mechanism instead of use of efficiency. The concept is clear and the method is simple and practical. It highlights design as the main clue. By using the less complicated geometry algebra method instead of traditional coordinate transformation method in the analytical design of four-bar mechanism and cam mechanism, we can simplify mathematical design methods easily. This textbook also provides readers with creative designs of mechanisms and designs of mechanism systems to implement the overall content from simple to complicated; the contents of modified gears, helical gears, bevel gears, worm gears and intermittent mechanism are simplified; the kinetostatic analysis of mechanism, force analysis including friction and self-locking are merged into a force anal-

ysis of mechanisms.

4) This textbook attempts to be different from the traditional versions by adopting color rendered figures and three-dimensional figures illustrations, which are clear and easy to read.

5) The exercises are divided into four parts: reading, comprehension, practice, and self-test. Furthermore, there are some analog test papers. These problems can help students to understand the basic concepts and to prepare them to cope with real engineering problems in practice.

6) As a bilingual textbook, a lot of described contents are simplified to reduce its length. It shortens traditional Chinese text to keep concise and compact to highlight consistent context and accurate terminology.

2. Descriptions about “theory of machines and mechanisms” in the English book

1) The main purpose of the bilingual textbook is to help students study the contents of “theory of machines and mechanisms”, rather than only English.

2) The English version is not the strict translation of the Chinese version, but their contents are coincident basically.

3) All the figures, tables and formulas between the Chinese version and English version correspond with each other; they have a good comparability.

4) The professional and conventional vocabularies are adopted from foreign textbooks; so the book has a good credibility.

5) Basic English grammar of science and technology makes reading easy.

6) The reading and comprehension which include the basic concepts are adopted from foreign textbooks.

7) Some concepts between the Chinese version and English version are a little different, such as redundant degree of freedom and local degree of freedom, redundant constraint and virtual constraint. This will benefit students to some extent.

The authors of the Chinese version are as follows.

Professor Zhang Chunlin (Chapter 1, 2 and 3), Zhao Ziqiang (Chapter 4, 5 and 6), Li Zhixiang (Chapter 7 and 8), Ma Chao (Chapter 9, 10, 11, 12 and 13).

Zhang Ying of Beijing University of Technology compiled and translated Chapter 1, 2, 3, 4, 5, 6, 7, 8, 9. Wang Zeyang compiled and translated Chapter 10 and 11. Feng Xinxin compiled and translated Chapter 12 and 13. Zhang Ying thoroughly compiled and edited the English Version and Professor Zhang Chunlin compiled and edited the entire bilingual text.

Acknowledgments

The authors would like to express their thanks for the cooperation of all those individuals who generously made this item available.

Sincere thanks also go to Professor Ge Wenjie of Northwestern Polytechnical University, who provided a part of 3D graphic. Some of the graphics are adopted from the other authors. We would like to express our thanks to them.

Finally, we would like to make an affectionate acknowledgment to China Machine Press for the support and we acknowledge the efforts of editorial staff for bringing out the new bilingual version in an excellent format.

It is hard to avoid errors and mistakes in the first edition, because the knowledge of English of authors is limited; the authors invites criticisms and suggestions from all readers for further improvement of the book, so that the errors can be improved in future versions.

Chun Lin Zhang  
Ever Bright Garden, Beijing





随着科学技术的飞速发展和教育逐渐走向世界,编写具有中国特色、又逐步与发达国家接轨的教材,是中国高等学校教学改革所面临的新课题。直接引入国外教材的方法不适合国内的教学现状,单纯的中文教材不能满足逐步与国际接轨的需要。因此,在机械工业出版社的支持下,作者开始尝试编写中英文双语机械原理教材。

本教材的指导思想是在教育部颁布的教学基本要求基础上,加强基本理论、基本方法和基本技能的培养;以设计为主线,突出创新意识和创新设计能力的培养;既反映中国同类教材的内容与特色,又逐步与国外同类教材接轨。

#### 1. 关于本教材中文部分的编写说明

1) 本教材按照机构分析、机构设计、机构系统设计和机构动力学设计的体系编写。

2) 教材内容中淡化图解法、强化解析法,如机构运动分析、力分析、连杆机构综合、凸轮机构设计、平衡设计等,淡化了图解法,突出了解析法。

3) 本教材对传统机械原理课程内容进行了修改、整合与拓展。在绪论中重新定义了机构与机器的基本概念,使其更具有时代特点;把机构组成原理拓展到机构创新设计;放弃传统的利用效率判断机构自锁的方法,改为利用总反力作用在摩擦锥或摩擦圆之内来判断机构的自锁现象,概念清晰,方法实用,把摩擦与自锁机构设计相结合,强化了设计主线;在连杆机构和凸轮机构的解析法设计中,放弃了传统的坐标变换法,采用了简单的几何代数法,简化了数学运算过程。

本教材还增加了创新设计、机构系统设计的内容,完善了从简单机构设计到复杂机构系统设计的整体内容;同时简化了齿轮机构中的变位齿轮、斜齿轮、锥齿轮、蜗杆机构以及其他常用机构的内容。把机构动态静力分析、摩擦与自锁、考虑摩擦的力分析等内容整合为机构的力分析。

4) 为了突出教材的新颖性,学习了国外同类教材的插图风格,重新绘制了平面彩色渲染图和一些三维图形,代替了传统的黑白线条图形,层次分明,有益于对教材内容的理解。

5) 改革了配套习题的体系与内容。本教材的配套习题集内容分为阅读、理解、设计和自测四个组成部分,习题集最后辅以部分模拟试卷,形成一套完整的课后训练系统。在加强基本理论、基本概念的基础上,采用与工程实践相结合的题目,突出了理论与实践相结合的训练目的,使学生逐步学习解决工程设计中的问题。

6) 由于本书为双语教材,为了不增加篇幅,简化了传统中文教材的叙述内容,使论述更加简练。

#### 2. 关于本教材英文部分的说明

1) 编写英汉双语教材,其目的是通过英文内容的学习,掌握机械原理的基本知识,为本专业领域内进行国际交流奠定基础。

2) 英文内容没有采取严格的汉语翻译内容, 而是强调基本内容的一致性和英文词汇准确性。

3) 教材体系和内容与对应的中文教材相一致, 如图、表、公式都有严格的对应, 具有可比性。

4) 编写中尽量采用国外同类教材中的常用标准专业词汇, 具有可信性。

5) 尽量采用常用的词汇和简单的初级科技语法, 容易理解, 具有可读性。

6) 本书配套习题集中的阅读与理解部分, 以基本概念与基本理论为主, 参考大量原版教材及文献。

7) 该书中, 有些中英文的概念存在差别, 有益于中外教材内容的接轨。如该书第2章中, 中文教材中的局部自由度、虚约束, 在英文教材中为多余自由度、多余约束。保留这些差别是有益的。

参加本书中文编写的教师有: 张春林(第1章, 第2章, 第3章), 赵自强(第4章, 第5章, 第6章), 李志香(第7章, 第8章), 马超(第9章, 第10章, 第11章, 第12章, 第13章)。

参加英文编写的教师有: 张颖(第1章, 第2章, 第3章, 第4章, 第5章, 第6章, 第7章, 第8章, 第9章), 王泽洋(第10章, 第11章), 冯欣欣(第12章, 第13章)。

本书英文部分由北京工业大学的张颖负责统稿。全书由张春林负责统稿。另外, 在编写过程中, 西北工业大学的葛文杰教授提供了部分3D图形, 还有一些老师提供了部分图形, 编者表示感谢。

由于编者水平有限, 书中难免存在错误、疏漏之处, 特别是英文部分难免存在中国式的英文表述, 敬请广大读者批评指正。

张春林  
于北京光大花园



# CONTENTS

## 目 录

### Preface 前言

<b>Chapter 1 Introduction 绪论</b> .....	1
1.1 General Information 机械总论 .....	2
1.2 Teaching Content and Object of the Course 机械原理课程的研究对象与内容 .....	6
1.3 Purpose of This Course 学习机械原理课程的目的 .....	8
<b>Chapter 2 Structural Analysis of Planar Mechanisms 平面机构的结构分析</b> .....	11
2.1 Kinematic Chain and Mechanisms 运动链与机构 .....	12
2.2 Schematic Diagram of Mechanisms 机构运动简图 .....	16
2.3 Degree of Freedom of Planar Mechanisms 机构自由度的计算 .....	22
2.4 Mechanism Analysis and Innovation 机构分析与创新 .....	30
<b>Chapter 3 Kinematic Analysis of Planar Mechanisms 平面机构的运动分析</b> .....	41
3.1 Introduction 平面机构运动分析概述 .....	42
3.2 Velocity Analysis with Instantaneous Centers 用速度瞬心法对机构进行速度分析 .....	44
3.3 Kinematic Analysis by Graphical Method 用相对运动图解法对机构进行运动分析 .....	48
3.4 Kinematic Analysis by Algebraic Method 用解析法对机构进行运动分析 .....	60
<b>Chapter 4 Force Analysis of Planar Mechanisms 平面机构的力分析</b> .....	67
4.1 Introduction 平面机构力分析概述 .....	68
4.2 Force Analysis Including Inertia Forces in Mechanisms 计入惯性力的机构力分析 .....	68
4.3 Force Analysis Including Friction in Mechanisms 计入摩擦的机构力分析 .....	76
4.4 Friction and Design of Self-locking Mechanisms 摩擦与自锁机构的设计 .....	88
<b>Chapter 5 Synthesis of Planar Linkages 平面连杆机构及其设计</b> .....	95
5.1 Characteristics and Types of Planar Linkages 平面连杆机构的特点与基本型式 .....	96
5.2 Fundamental Features of Four-bar Linkages 平面连杆机构的基本性质 .....	104
5.3 Synthesis of Four-bar Linkages 平面连杆机构的设计 .....	112
<b>Chapter 6 Design of Cam Mechanisms 凸轮机构及其设计</b> .....	131
6.1 Introduction 凸轮机构概述 .....	132
6.2 Basic Types of Follower Motion and Design 从动件的运动规律及其设计 .....	138
6.3 Cam Profile Synthesis 凸轮轮廓曲线的设计 .....	150

6.4	Sizes of Cam Mechanisms 凸轮机构基本尺寸的设计 .....	158
6.5	Computer-aided Design of Cam Mechanisms 计算机辅助凸轮设计 .....	164
<b>Chapter 7</b>	<b>Design of Gear Mechanisms 齿轮机构及其设计 .....</b>	<b>171</b>
7.1	Classification of Gear Mechanisms 齿轮机构的分类 .....	172
7.2	Fundamental Law of Gearing 齿廓基本定律 .....	174
7.3	Involute Properties and Involute Tooth Profiles 渐开线齿廓及其啮合特点 .....	176
7.4	Nomenclatures of Standard Spur Gear and Gear Sizes 渐开线标准直齿圆柱齿轮的基本参数和几何尺寸 .....	180
7.5	Meshing Drive of Standard Spur Gears 渐开线直齿圆柱齿轮机构的啮合传动 .....	186
7.6	Forming and Undercutting of Gear Teeth 渐开线圆柱齿轮的加工及其根切现象 .....	196
7.7	Nonstandard Spur Gears 变位齿轮概述 .....	202
7.8	Parallel Helical Gears 平行轴斜齿圆柱齿轮机构 .....	206
7.9	Worm and Worm Gears 蜗杆传动机构 .....	214
7.10	Bevel Gears 锥齿轮机构 .....	220
<b>Chapter 8</b>	<b>Design of Gear Trains 轮系及其设计 .....</b>	<b>227</b>
8.1	Classification of Gear Trains 轮系及其分类 .....	228
8.2	Ratio of Ordinary Gear Trains 定轴轮系传动比的计算 .....	230
8.3	Ratio of Epicyclic Gear Trains 周转轮系传动比的计算 .....	236
8.4	Ratio of Combined Gear Trains 混合轮系传动比的计算 .....	240
8.5	Some Considerations for Design of Planetary Gear Trains 周转轮系设计中的若干问题 .....	244
8.6	Introduction of Miscellaneous Planetary Trains 其他类型的周转轮系简介 .....	252
<b>Chapter 9</b>	<b>Introduction of Screws, Hook's Couplings and Intermittent Mechanisms</b> <b>螺旋机构、万向联轴器、间歇运动机构简介 .....</b>	<b>259</b>
9.1	Screw Mechanisms 螺旋机构 .....	260
9.2	Universal Joints 万向联轴器 .....	262
9.3	Ratchet Mechanisms 棘轮机构 .....	264
9.4	Geneva Mechanisms 槽轮机构 .....	268
9.5	Indexing Cam Mechanisms 凸轮式间歇运动机构 .....	272
9.6	Intermittent Gear Mechanisms 不完全齿轮机构 .....	274
<b>Chapter 10</b>	<b>Spatial Mechanisms and Robotic Mechanisms</b> <b>空间连杆机构及机器人机构概述 .....</b>	<b>279</b>
10.1	Introduction of Spatial Mechanisms 空间连杆机构概述 .....	280
10.2	Introduction of Robotic Mechanisms 机器人机构概述 .....	286
<b>Chapter 11</b>	<b>Design of Mechanism Systems 机构系统设计 .....</b>	<b>293</b>
11.1	Introduction of Mechanism Systems 机构系统设计概述 .....	294
11.2	Harmonization Design of Mechanism Motions 机构系统的运动协调设计 .....	296
11.3	Combined Methods of Mechanism Systems 机构系统的组合方法 .....	298

**Chapter 12 Fluctuation and Regulation in Speed of Machines**

机械系统的运转及速度波动的调节 ..... 307

12.1 Operating Analysis of Machinery 机械运转过程分析 ..... 308

12.2 Equivalent Kinetic Model of Mechanism Systems 机械系统的等效动力学模型 ..... 312

12.3 Kinetic Equations of Mechanism Systems 机械系统的运动方程及其求解 ..... 320

12.4 Periodic Speed Fluctuation and Regulation in a Machine 周期性速度波动及飞轮设计 ..... 324

12.5 Aperiodic Speed Fluctuation and Regulation in a Machine 非周期性速度波动及其调节 ..... 332

**Chapter 13 Balance of Machinery 机械的平衡** ..... 337

13.1 Introduction 机械平衡概述 ..... 338

13.2 Balance Design of Rigid Rotors 刚性转子的平衡设计 ..... 340

13.3 Balance Test of Rigid Rotors 刚性转子的平衡实验 ..... 344

13.4 Balance of Planar Mechanisms 平面机构的平衡简介 ..... 350

**Appendix 附录** ..... 352**References 参考文献** ..... 362

# Chapter 1

## Introduction

# 第1章

## 绪论

## 1.1 General Information

A variety of machineries, such as textile machinery, printing machinery, food machinery, transportation machinery, mining machinery, construction machinery, engineering machinery, agricultural machinery, forestry machinery, packaging machinery, metallurgical machinery, fluid machinery, service machinery, weapons, robots and so on, have played an important role in nowadays economic development and national defense. They have promoted the development of human society. How to improve old pattern of machinery and design new machinery are essential tasks in the field of mechanical engineering.

### 1. The Concept of Machinery

Along with the progress of human society, the concept of machinery is developed and improved gradually. Human beings began to use stone tools from the primitive society at first, such as stone axes and stone knives. With the development of technology, our ancestor invented some simple wooden tools, such as lever, windlass, human power waterwheel, animal power waterwheel and so on. On the basis of these simple tools, some complicated devices were invented, such as water-powered roller and windmills. In the 18th century, after the British industrial revolution, human invented steam engine, internal combustion engine and electromotor, therefore the foundation of modern mechanical industry was established. After the computer was invented, the automatic control technology, information technology, and the transducer technology were used in machinery, which made the machines realize automation and intelligent. New technology and equipments, such as robots, numerical control machines, high-speed vehicles and aircrafts, heavy machinery, micro machinery and so on, have promoted the human society's prosperity and progress.

In different period, the definition of machinery is different, as well. In general, machinery is the device which can realize the mechanical movement. For example, screwdriver, hammer, pliers, scissors are machinery and tanks, planes, cars, ships, robots, and other senior complicated equipment are also machinery. However, in modern society, people used to define the simplest machinery with no power as tools, such as lever, pliers, scissors, wheelbarrow, and so on.

In mechanical engineering, when talking about specific machinery, it is called a machine.

(1) Mechanism A mechanism is a device, which produces specific mechanical motions. Thus, the function of a mechanism is to transmit and modify a motion. We often use a drawing with some simple lines and symbols to describe the mechanism, and it is called kinematical diagram.

(2) Machine A machine is a device which produces specific mechanical motions, and it can transmit or modify mechanical energy, materials and information. A machine may be a mechanism or a combination of mechanisms capable of transmitting or modifying motion and mechanical energy.

For instance, vehicles, tanks, missiles, planes, ships and so on are all machines. But the television is not a machine, because it has nothing to do with mechanical movement.

Fig. 1-1a shows an internal combustion engine which transforms thermal energy into mechanical energy. The sliding motion of piston 1 will be transformed to the series rotation of crank shaft 3 by coupler 2. This kind of mechanism is called a linkage.

各种各样的机械,如纺织机械、印刷机械、食品机械、交通运输机械、矿山机械、建筑机械、工程机械、农业机械、林业机械、包装机械、冶金机械、流体机械、服务机械、兵器与机器人等,在经济建设和国防建设领域中发挥了巨大作用,促进了人类社会的发展。改造原有机械、设计新机械是机械工程领域中的重要任务。了解机械、设计机械是机械工程专业教学中的重要内容。

### 1. 机械的概念

机械的概念是伴随人类社会的不断进步逐渐发展与完善的。从早期原始社会人类使用的诸如石斧、石刀等最简单的石制工具,到杠杆、辘轳、人力脚踏水车、兽力汲水车等简单木制工具,发展到较复杂的水力驱动和风力驱动的水碾和风车等都是简单机械。18世纪英国工业革命后,人类发明的蒸汽机、内燃机、电动机等复杂的机械,奠定了现代机械的基础。计算机发明后,自动控制技术、信息技术、传感技术融入机械中,机械实现了自动化和智能化。机器人、数控机床、高速运载工具,重型机械、微型机械等大量先进机械加速了人类社会的繁荣和进步,机械进入机电结合的新时代。

不同历史时期,人们对机械的定义也有所不同。从广义角度讲,凡是能实现机械运动的装置都是机械。如螺钉旋具、锤子、钳子、剪子等简单工具是机械,汽车、坦克、飞机、舰船、各类加工机床、机械手、机器人、复印机、打印机等高级复杂装备也是机械。无论其结构和材料如何,只要是实现机械运动的装置,就称之为机械。在现代社会中,人们常把最简单的、没有动力源的简单机械称为工具或器械,如杠杆、钳子、剪子、手推车等最简单的机械常称为工具。

工程中,谈到具体的机械时,常使用机器这个名词,泛指时则用机械来统称。

(1) 机构 机器的重要特征是执行机械运动,工程上把机器中执行机械运动的装置称为机构。为研究方便,常用简单的符号和线条表示机构的组成情况和运动情况,并称之为机构运动简图。

(2) 机器 机器是执行机械运动的装置,用来变换或传递能量、物料或信息。机器的重要特征是执行机械运动,同时完成能量的转换,或物料、信息的传递。汽车、坦克、导弹、飞机、轮船、车床、起重机、织布机、印刷机、包装机等大量具有不同外形、不同性能和用途的装置都是具体的机器。电视机不是机器,因其功能与机械运动无关。

图1-1a所示的四冲程的内燃机,是一个把热能转换为机械能的机器。该内燃机中,活塞1的往复移动通过连杆2推动曲轴3连续旋转。这种把活塞移动转化为曲轴连续转动的装置称为连杆机构。

凸轮7转动,驱动推杆8往复移动,称为凸轮机构。再通过杠杆9,驱动气门10的开启,控制进、排气阀的运动,保证缸体11按顺序吸进燃气和排出废气。四冲程内燃机中,活塞往复移动四次,曲轴转动两周,进气阀和排气阀各启闭一次,所以凸轮的转速为曲轴的转速的一半。也就是说,在曲轴和凸轮轴之间要设置减速齿轮4、5、6,称为齿轮机构。齿轮机构实现了高速转动到低速转动的运动变换。

综上所述,机构是组成机器的主体。为表明机器的组成和运动情况,常用机构运动简图来表示。

Cam 7 and follower 8 are called cam mechanism. The opening and closing of valve 10 can be controlled by lever 9. This can ensure that cylinder 11 takes in the gas and exhales the waste gas. In a four-stroke engine, it takes four strokes of the piston to complete one cycle. That is to say, the circle is completed in two revolutions of the crank shaft, and the valves work at a time. Therefore, the engine requires a gear mechanism to reduce the speed of the crankshaft, such as gears 4, 5, 6.

There are four strokes in the engine. They are intake stroke, compression stroke, power stroke and exhaust stroke, but only one power stroke works, so the speed of the crank shaft fluctuates cyclically. A flywheel must be mounted on the crank shaft.

Fig. 1-1b shows the skeleton diagram of the four-stroke engine. The design can be simplified by use of skeleton diagram.

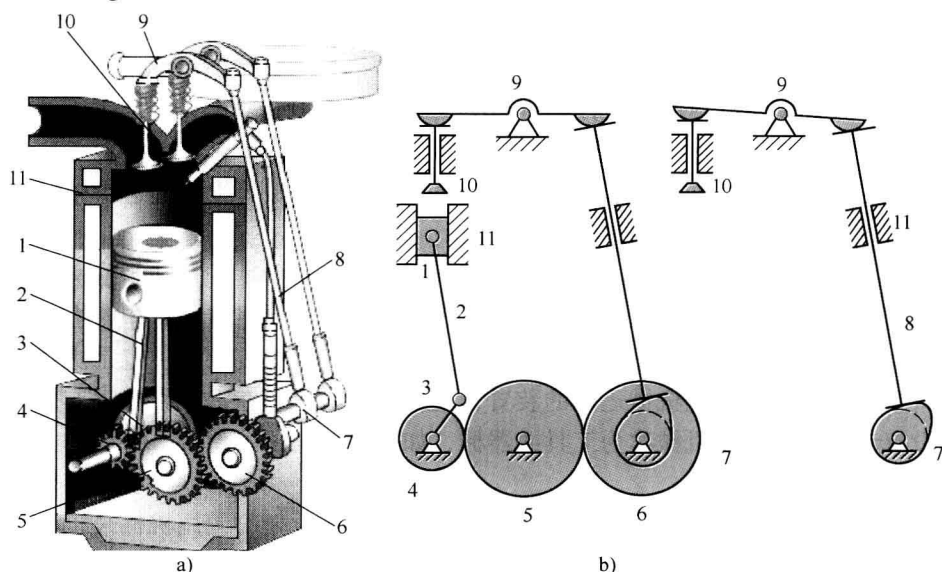

Fig. 1-1 Internal combustion engine and scheme (内燃机及其机构简图)

1—piston(活塞) 2—coupler(连杆) 3—crank shaft(曲轴) 4,5,6—gear(齿轮) 7—cam(凸轮)  
8—follower(推杆) 9—lever(杠杆) 10—valve(气门) 11—frame(缸体)

Although there are various types of machines, the mechanisms consisting of machines are finite. Therefore, the theory of mechanism is very important to design machines.

(3) Machinery In the viewpoint of kinematics, mechanism and machine have no difference, so mechanisms and machines are generally called machinery in mechanical engineering. There is no energy transforming and modifying in a mechanism, for example, mechanical watch is a mechanism but not a machine, because it can not transform energy.

## 2. Composition of Machines

A machine consists of prime power, transmission system and working system. A modern machine also contains a control system. Fig. 1-2 shows the block diagram of composition of a machine.

Fig. 1-3b shows a diagram of an automatic gate. Fig. 1-3a shows the composition of the driver. The prime power is electromotor 3 which has a high speed. But gate 2 needs a low speed to work, so we have to install gear mechanisms and chain mechanisms to modify the speed of electromotor 3. The reducer 4 and chain driver 5 are transmission system. Gate 2 consisting of the parallel linkages is called working system. The control system and sense system are not illustrated in the gate.



图 1-1b 为该内燃机的机构简图。为表达清楚，另一套凸轮机构单独画出。使用机构简图对内燃机进行分析和设计时，简化了设计工作。由于缸体中进气、压缩、燃烧、排气交替进行，导致曲轴运动速度不均匀，所以在曲轴的另一端还要安装调速飞轮。上述各机构协调动作，才能实现内燃机的工作要求。

机器的种类很多，其功能、形状、结构、尺寸等也各不相同，但组成不同机器的机构种类却是有限的，仅有 10 余种。因此研究用有限的机构组成无限的机器，就必须掌握机构的种类、工作原理以及设计方法。

(3) 机械 机构与机器的共同点都是实现机械运动的装置，所以从运动学的观点看，二者是一样的；不同点是机构没有能量的转换和信息的传递。如机械表是机构，不是机器。因为弹簧能量没有转换为机械能输出，其作用仅为克服各运动件的摩擦阻力。

从机械运动的观点看问题，机构与机器没有本质区别，工程中将机构与机器统称为机械。

## 2. 机器的组成

根据机器的定义，机器中要有动力源，称为原动机；机器中还要有机械运动的传递装置或机械运动形态的变换装置，常将它们称为机械传动系统和工作执行系统，统称为机械运动系统；现代机器还有控制系统。图 1-2 所示框图为常见机器组成示意图。

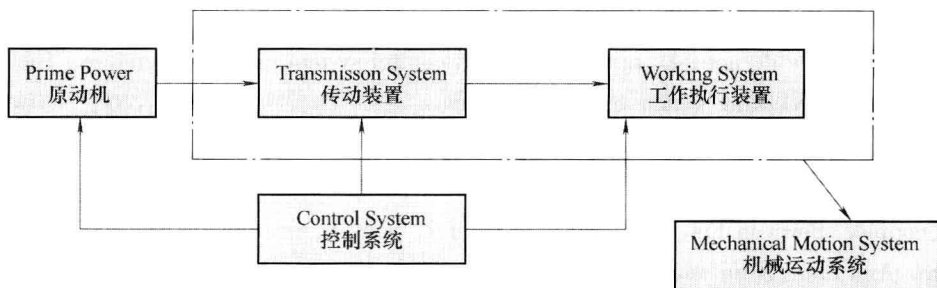

Fig. 1-2 Composition of machine (机器组成示意图)

图 1-3 为电动大门示意图，其驱动器 1 的内部组成见图 1-3a。原动机为电动机 3，其转速很高，而大门 2 的开启速度较低，所以要经过齿轮传动机构组成的减速器 4 和链传动机构 5 把电动机 3 的转速降下来，图示的减速器和链传动机构就是速度变换机构。由许多平行四边形机构和滚轮组成的大门 2 称为工作执行机构。

工程中应用的机械运动系统中，大都具有减速机构。但也有一些现代机器没有减速机构，直接用可控电动机驱动工作执行机构。

In mechanical engineering, most of machines have a transmission system, however, a variety of modern machines use control motor instead of transmission system.

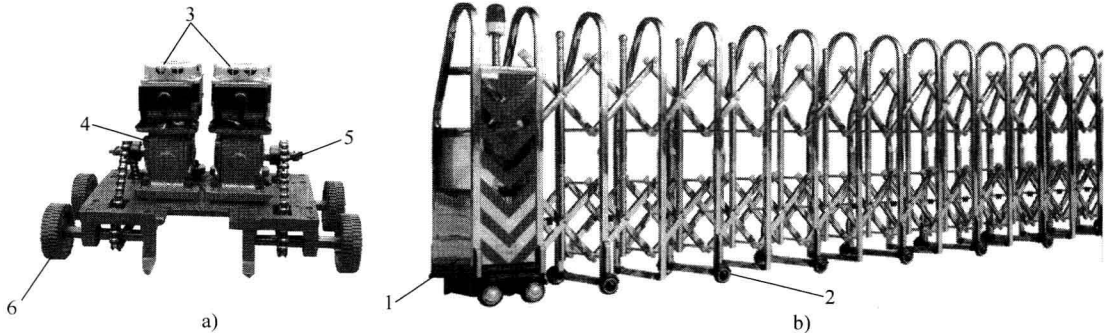

Fig. 1-3 Automatic gate (电动大门示意图)

1—driver(驱动器) 2—gate(大门) 3—electromotor(电动机) 4—reducer(减速器)  
5—chain driver(链传动) 6—rollers(滚轮)

## 1.2 Teaching Content and Object of the Course

### 1. Research Object of the Course

The research object of the course is the theory of machinery, and machinery contains mechanisms and machines. Therefore, the theory of mechanisms and machines is the important content of this course.

In this course we do not take prime power and control system into consideration. The transmission system and the working system are emphasized.

The piston, coupler, crank, cam, gear and so on shown in Fig. 1-1 are smallest motion units, and they are called links. The motion of links is an important content for us.

The coupler shown in Fig. 1-4 consists of head 4, body 1, bearing 2, bearing bush 3, bolt 5, nut 6, etc. And there is no relative motions among these parts which are smallest units composing a link. The part or element is the smallest unit from the viewpoint of manufacture.

A link can be either a rigid composition of elements (parts) or only one element (part), for instance, a gear is a mechanical element, and it is also a kinematical link. So we can distinguish between link and element easily.

### 2. Content of This Course

As mentioned earlier, a mechanism transmits and modifies a motion and a machine is a mechanism or combination of mechanisms, thus this content of this course is about mechanisms. The study of mechanisms involves its structural analysis, motion analysis, force analysis, dimension synthesis and design of mechanism system.

Generally, the content of the course is divided into three parts. They are structural analysis of mechanisms, kinematics of mechanisms and dynamics of machinery respectively.

(1) Structural analysis of mechanisms It involves the composition of mechanism, kinematical diagram, calculation of degree of freedom and analysis of mechanism.