

0.036094	0.011697	0.073002	0.143443	0.21806	0.28261	0.33377	0.38041
0.086655	0.15466	0.23615	0.32623	0.41791	0.50222	0.56866	0.60627
0.18037	0.26114	0.35335	0.45862	0.56454	0.66445	0.74727	0.80011
0.23147	0.31528	0.40101	0.50184	0.60256	0.74412	0.84388	0.91714
0.28000	0.36700	0.45700	0.55000	0.64500	0.77000	0.86000	0.92000

RELEASE 13

Learning

SIMULINK[®] 5

MATLAB[®] & SIMULINK

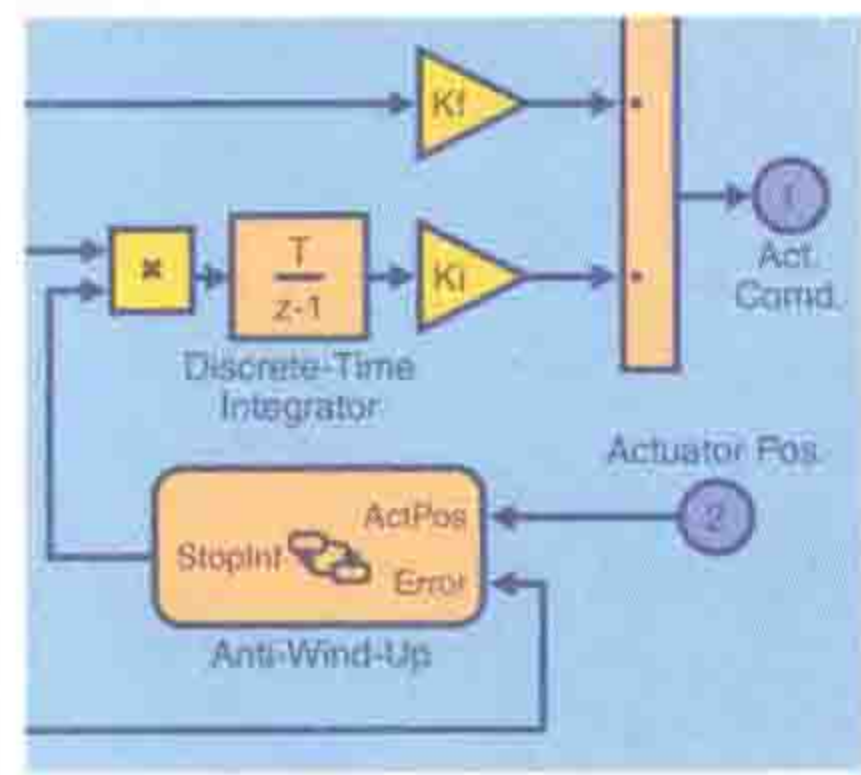
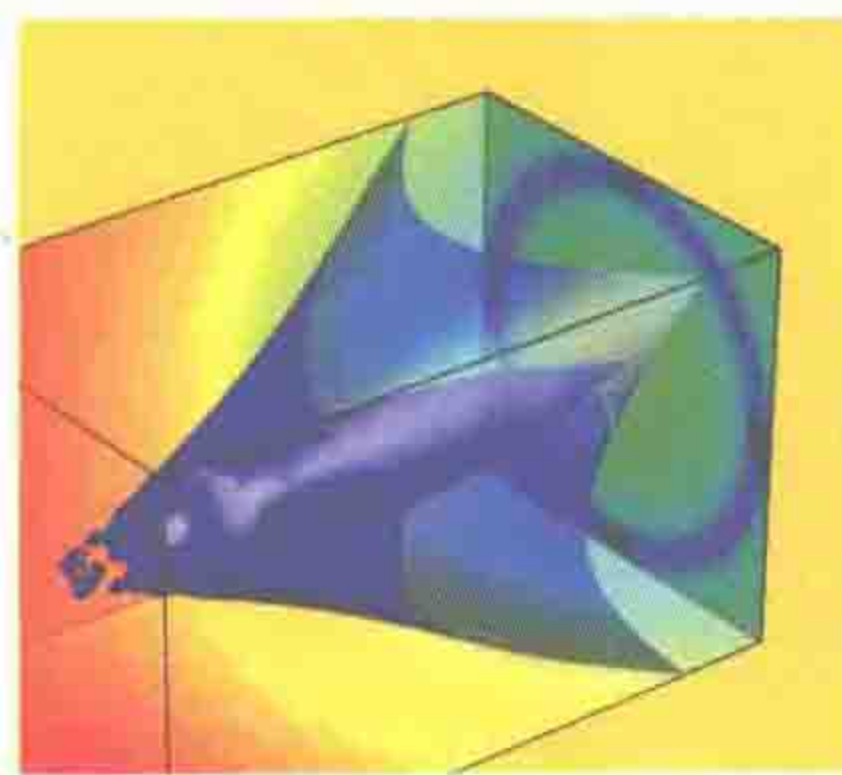
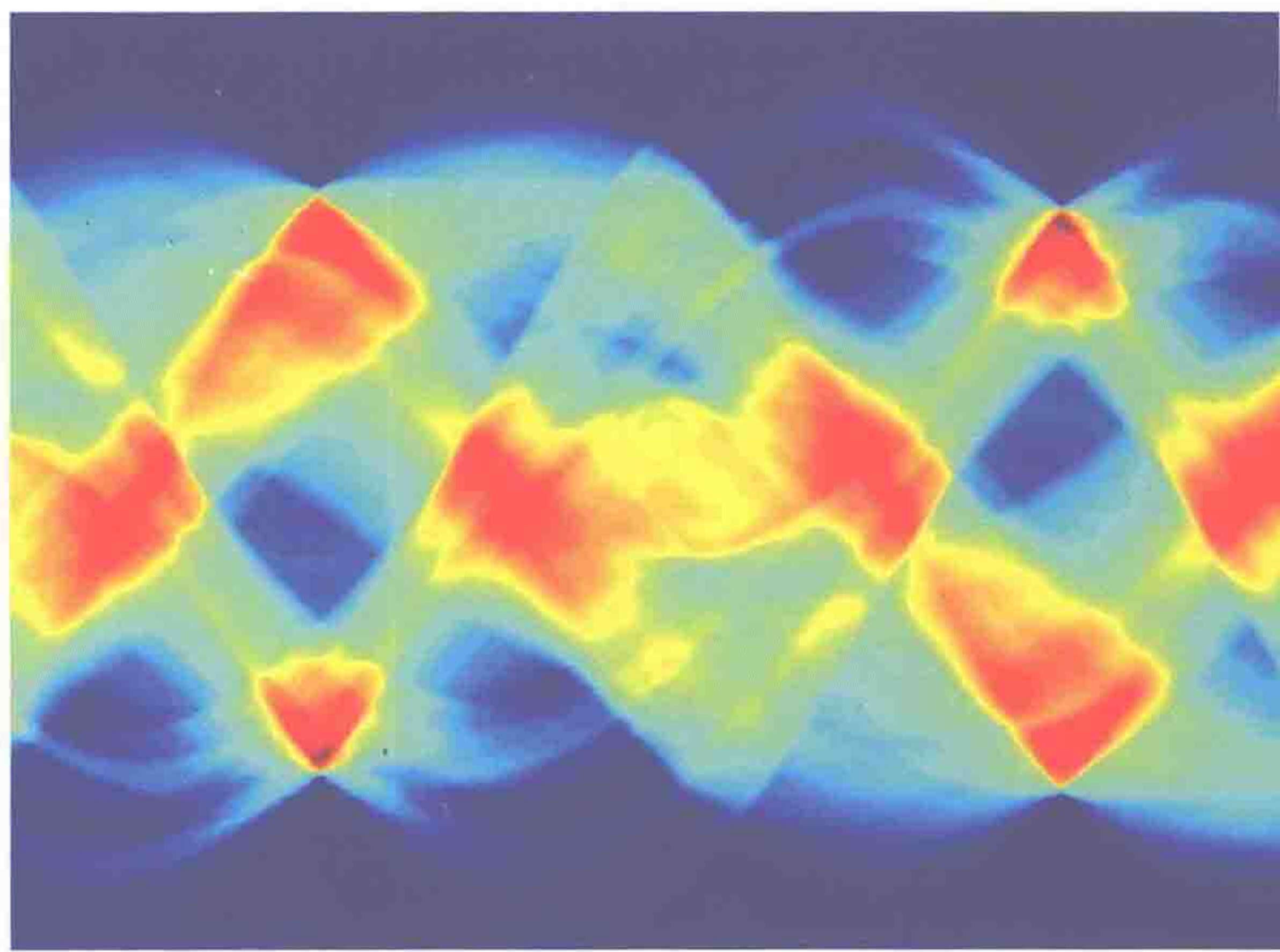
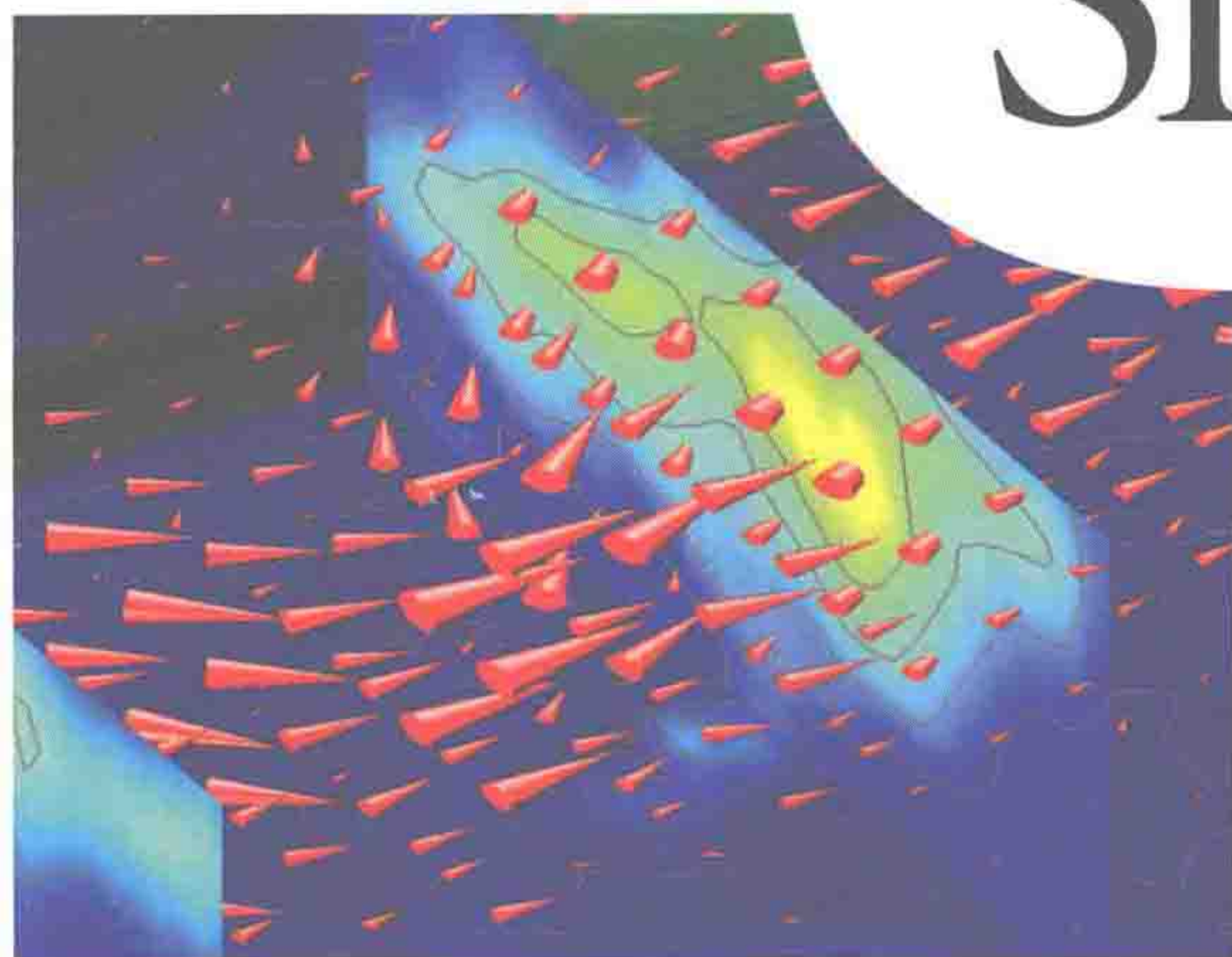

MATLAB[®]
STUDENT VERSION
 with **SIMULINK[®]**

 The MathWorks

RELEASE
13

Learning

SIMULINK[®] 5

MATLAB[®]
STUDENT VERSION
with **SIMULINK[®]**

 The MathWorks

Introduction

1

About the Student Version	1-2
Student Use Policy	1-2
Differences Between the Student Version and the Professional Version	1-3
Obtaining Additional MathWorks Products	1-6
Getting Started with Simulink	1-7
Finding Reference Information	1-8
Troubleshooting and Other Resources	1-9
Documentation Library	1-9
MathWorks Web Site	1-11
MathWorks Education Web Site	1-11
MATLAB Related Books	1-11
MathWorks Store	1-11
MATLAB Central — File Exchange/Newsgroup Access	1-11
MathWorks Web-Based Technical Support	1-12
Technical Support	1-12
Product Registration	1-12
About Simulink	1-13
What Is Simulink?	1-13

Quick Start

2

Running a Demo Model	2-2
Description of the Demo	2-3
Some Things to Try	2-4

What This Demo Illustrates	2-5
Other Useful Demos	2-5
Building a Simple Model	2-7
Setting Simulink Preferences	2-16
Simulink Preferences	2-16

How Simulink Works

3

What Is Simulink	3-2
Modeling Dynamic Systems	3-3
Block Diagrams	3-3
Blocks	3-3
States	3-4
System Functions	3-4
Block Parameters	3-5
Continuous Versus Discrete Blocks	3-6
Subsystems	3-6
Custom Blocks	3-7
Signals	3-7
Solvers	3-7
Simulating Dynamic Systems	3-8
Model Initialization Phase	3-8
Model Execution Phase	3-9
Processing at Each Time Step	3-9
Determining Block Update Order	3-10
Atomic Versus Virtual Subsystems	3-12
Solvers	3-12
Zero-Crossing Detection	3-14
Algebraic Loops	3-18
Modeling and Simulating Discrete Systems	3-24
Specifying Sample Time	3-24

Purely Discrete Systems	3-27
Multirate Systems	3-27
Determining Step Size for Discrete Systems	3-28
Sample Time Propagation	3-29
Invariant Constants	3-31
Mixed Continuous and Discrete Systems	3-32

Simulink Basics

4

Starting Simulink	4-2
Opening Models	4-4
Entering Simulink Commands	4-5
Using the Simulink Menu Bar to Enter Commands	4-5
Using Context-Sensitive Menus to Enter Commands	4-5
Using the Simulink Toolbar to Enter Commands	4-5
Using the MATLAB Window to Enter Commands	4-6
Undoing a Command	4-6
Simulink Windows	4-7
Status Bar	4-7
Zooming Block Diagrams	4-7
Saving a Model	4-9
Saving a Model in Earlier Formats	4-9
Printing a Block Diagram	4-12
Print Dialog Box	4-12
Print Command	4-13
Specifying Paper Size and Orientation	4-14
Positioning and Sizing a Diagram	4-15
Generating a Model Report	4-16
Model Report Options	4-17

Summary of Mouse and Keyboard Actions	4-19
Manipulating Blocks	4-19
Manipulating Lines	4-20
Manipulating Signal Labels	4-20
Manipulating Annotations	4-21
 Ending a Simulink Session	 4-22

Creating a Model

5

Creating a New Model	5-2
 Selecting Objects	 5-3
Selecting One Object	5-3
Selecting More Than One Object	5-3
 Specifying Block Diagram Colors	 5-5
Choosing a Custom Color	5-5
Defining a Custom Color	5-6
Specifying Colors Programmatically	5-6
Enabling Sample Time Colors	5-7
 Connecting Blocks	 5-9
Automatically Connecting Blocks	5-9
Manually Connecting Blocks	5-11
Disconnecting Blocks	5-15
 Annotating Diagrams	 5-16
Using TeX Formatting Commands in Annotations	5-17
 Creating Subsystems	 5-19
Creating a Subsystem by Adding the Subsystem Block	5-19
Creating a Subsystem by Grouping Existing Blocks	5-20
Model Navigation Commands	5-22
Window Reuse	5-22
Labeling Subsystem Ports	5-23

Controlling Access to Subsystems	5-23
Creating Conditionally Executed Subsystems	5-25
Enabled Subsystems	5-25
Triggered Subsystems	5-30
Triggered and Enabled Subsystems	5-33
Control Flow Blocks	5-37
Using Callback Routines	5-48
Tracing Callbacks	5-48
Creating Model Callback Functions	5-48
Creating Block Callback Functions	5-50
Port Callback Parameters	5-53

Working with Blocks

6

About Blocks	6-2
Block Data Tips	6-2
Virtual Blocks	6-2
Editing Blocks	6-4
Copying and Moving Blocks from One Window to Another ...	6-4
Moving Blocks in a Model	6-5
Copying Blocks in a Model	6-6
Deleting Blocks	6-6
Setting Block Parameters	6-7
Setting Block-Specific Parameters	6-7
Block Properties Dialog Box	6-8
State Properties Dialog Box	6-11
Changing a Block's Appearance	6-12
Changing the Orientation of a Block	6-12
Resizing a Block's Icon	6-12
Displaying Parameters Beneath a Block's Icon	6-13
Using Drop Shadows	6-13

Manipulating Block Names	6-13
Specifying a Block's Color	6-15
Controlling and Displaying Block Execution Order	6-16
Assigning Block Priorities	6-16
Displaying Block Execution Order	6-17
Look-Up Table Editor	6-18
Browsing LUT Blocks	6-19
Editing Table Values	6-20
Displaying N-D Tables	6-21
Plotting LUT Tables	6-22
Editing Custom LUT Blocks	6-23
Working with Block Libraries	6-25
Terminology	6-25
Simulink Block Library	6-25
Creating a Library Link	6-26
Disabling Library Links	6-27
Modifying a Linked Subsystem	6-27
Propagating Link Modifications	6-27
Updating a Linked Block	6-28
Breaking a Link to a Library Block	6-28
Finding the Library Block for a Reference Block	6-29
Library Link Status	6-29
Displaying Library Links	6-30
Getting Information About Library Blocks	6-31
Browsing Block Libraries	6-31
Adding Libraries to the Library Browser	6-33

Working with Signals

7

Signal Basics	7-2
About Signals	7-2
Control Signals	7-4
Signal Buses	7-5

Signal Glossary	7-5
Determining Output Signal Dimensions	7-6
Signal and Parameter Dimension Rules	7-7
Scalar Expansion of Inputs and Parameters	7-9
Working with Complex Signals	7-11
Checking Signal Connections	7-12
Displaying Signals	7-13
Signal Names	7-14
Signal Labels	7-14
Displaying Signals Represented by Virtual Signals	7-15

Running a Simulation

8

Simulation Basics	8-2
Specifying Simulation Parameters	8-2
Controlling Execution of a Simulation	8-3
Interacting with a Running Simulation	8-6
The Simulation Parameters Dialog Box	8-7
The Solver Pane	8-7
The Workspace I/O Pane	8-17
The Diagnostics Pane	8-24
The Advanced Pane	8-28
Diagnosing Simulation Errors	8-35
Simulation Diagnostic Viewer	8-35
Creating Custom Simulation Error Messages	8-36
Improving Simulation Performance and Accuracy	8-39
Speeding Up the Simulation	8-39
Improving Simulation Accuracy	8-40

Analyzing Simulation Results

9

Viewing Output Trajectories	9-2
Using the Scope Block	9-2
Using Return Variables	9-2
Using the To Workspace Block	9-3
Linearizing Models	9-4
Finding Steady-State Points	9-7

Creating Masked Subsystems

10

About Masks	10-2
Mask Features	10-2
Creating Masks	10-4
Masked Subsystem Example	10-5
Creating Mask Dialog Box Prompts	10-6
Creating the Block Description and Help Text	10-8
Creating the Block Icon	10-8
Masking a Subsystem	10-10
The Mask Editor	10-12
The Icon Pane	10-14
The Parameters Pane	10-17
Control Types	10-20
The Initialization Pane	10-23
The Documentation Pane	10-25
Linking Mask Parameters to Block Parameters	10-27

Introduction	11-2
Starting the Debugger	11-3
Starting the Simulation	11-4
Using the Debugger's Command-Line Interface	11-6
Block Indexes	11-6
Accessing the MATLAB Workspace	11-6
Getting Online Help	11-7
Running a Simulation	11-8
Continuing a Simulation	11-8
Running a Simulation Nonstop	11-9
Advancing to the Next Block	11-9
Advancing to the Next Time Step	11-11
Setting Breakpoints	11-12
Setting Breakpoints at Blocks	11-13
Setting Breakpoints at Time Steps	11-14
Breaking on Nonfinite Values	11-15
Breaking on Step-Size Limiting Steps	11-15
Breaking at Zero Crossings	11-15
Displaying Information About the Simulation	11-17
Displaying Block I/O	11-17
Displaying Algebraic Loop Information	11-19
Displaying System States	11-20
Displaying Integration Information	11-20
Displaying Information About the Model	11-21
Displaying a Model's Block Execution Order	11-21
Displaying a Block	11-22

A

Continuous	A-2
Discontinuities	A-3
Discrete	A-4
Look-Up Tables	A-5
Math Operations	A-6
Model Verification	A-8
Model-Wide Utilities	A-10
Ports & Subsystems	A-11
Signal Attributes	A-13
Signal Routing	A-14
Sinks	A-15
Sources	A-16
User-Defined Functions	A-18
Blocksets and Toolboxes	A-19
Demos Library	A-20

Introduction

This chapter introduces the MATLAB Student Version and provides resources for using it.

About the Student Version (p. 1-2)

Description of the Student Version and how it differs from the professional version.

Obtaining Additional MathWorks Products (p. 1-6)

How to acquire other products that work with the Student Version.

Getting Started with Simulink (p. 1-7)

Steps for learning how to use Simulink.

Finding Reference Information (p. 1-8)

Techniques for learning more about Simulink.

Troubleshooting and Other Resources (p. 1-9)

Additional sources of information for the Student Version products.

About Simulink (p. 1-13)

High-level description of Simulink.

About the Student Version

MATLAB[®] and Simulink[®] are premier software packages for technical computation in education and industry. The MATLAB Student Version provides all of the features of professional MATLAB, with no limitations, and the full functionality of professional Simulink, with model sizes up to 300 blocks. The Student Version gives you immediate access to the high-performance numeric computing, modeling, and simulation power you need.

MATLAB allows you to focus on your course work and applications rather than on programming details. It enables you to solve many numerical problems in a fraction of the time it would take you to write a program in a lower level language. MATLAB helps you better understand and apply concepts in applications ranging from engineering and mathematics to chemistry, biology, and economics.

Simulink, included with the Student Version, is a block diagram tool for modeling and simulating dynamic systems, including controls, signal processing, communications, and other complex systems.

The Symbolic Math Toolbox, also included with the Student Version, is based on the Maple[®] 8 symbolic kernel and lets you perform symbolic computations and variable-precision arithmetic.

MATLAB products are used in a broad range of industries, including automotive, aerospace, electronics, environmental, telecommunications, computer peripherals, finance, and medical. More than 500,000 technical professionals at the world's most innovative technology companies, government research labs, financial institutions, and at more than 2,000 universities, rely on MATLAB and Simulink as the fundamental tools for their engineering and scientific work.

Student Use Policy

This Student License is for use in conjunction with courses offered at a degree-granting institution. The MathWorks offers this license as a special service to the student community and asks your help in seeing that its terms are not abused.

To use this Student License, you must be a student using the software in conjunction with courses offered at degree-granting institutions.

You may not use this Student License at a company or government lab. Also, you may not use it for research or for commercial or industrial purposes. In these cases, you can acquire the appropriate professional or academic version of the software by contacting The MathWorks.

Differences Between the Student Version and the Professional Version

MATLAB

The MATLAB Student Version provides full support for all language features as well as graphics, external interface and Application Program Interface (API) support, and access to every other feature of the professional version of MATLAB.

MATLAB Differences. There are a few small differences between the Student Version and the professional version of MATLAB:

- The MATLAB prompt in the Student Version is
EDU>>
- The window title bars include the words
<Student Version>
- All printouts contain the footer
Student Version of MATLAB

This footer is not an option that can be turned off; it will always appear in your printouts.

- The Documentation CD must be in your CD-ROM drive to start MATLAB. Once MATLAB starts, you can remove the CD. However, to access the online documentation, the CD must be in the CD-ROM drive.

Simulink

This Student Version contains the complete Simulink product, which is used with MATLAB to model, simulate, and analyze dynamic systems.

Simulink Differences.

- Models are limited to 300 blocks.
-

Note You may encounter some demos that use more than 300 blocks. In these cases, a dialog will display stating that the block limit has been exceeded and the demo will not run.

- The window title bars include the words
<Student Version>
 - All printouts contain the footer
Student Version of MATLAB

This footer is not an option that can be turned off; it will always appear in your printouts.
-

Note The Using Simulink documentation, which is accessible from the Help browser, contains all of the relevant information in the Learning Simulink book plus additional advanced information.

Symbolic Math Toolbox

The Symbolic Math Toolbox included with this Student Version lets you access all of the functions in the professional version of the Symbolic Math Toolbox except `maple`, `mapleinit`, `mfun`, `mfunlist`, and `mhelp`. For a complete list of all the available functions, see Appendix B, “Symbolic Math Toolbox Quick Reference,” in Learning MATLAB.