

STRUCTURAL

包装

DESIGN

结构

FOR

设计

PACKAGING

鞠海 编

辽宁科学技术出版社

STRUCTURAL

包装

DESIGN

结构

FOR

设计

PACKAGING



图书在版编目 (C I P) 数据

包装结构设计 / 鞠海编. — 沈阳: 辽宁科学技术出版社, 2016. 4

ISBN 978-7-5381-9596-5

I. ①包… II. ①鞠… III. ①包装容器—结构设计
IV. ①TB482. 2

中国版本图书馆 CIP 数据核字 (2016) 第 014392 号

出版发行: 辽宁科学技术出版社
(地址: 沈阳市和平区十一纬路 29 号 邮编: 110003)

印刷者: 辽宁新华印务有限公司

经销者: 各地新华书店

幅面尺寸: 215mm×280mm

印 张: 31.5

字 数: 50 千字

出版时间: 2016 年 4 月第 1 版

印刷时间: 2016 年 4 月第 1 次印刷

责任编辑: 殷文文

封面设计: 谭婷薇

版式设计: 鞠 海

责任校对: 周 文

书 号: ISBN 978-7-5381-9596-5

定 价: 198.00 元

联系电话: 024-23284360

邮购热线: 024-23284502

E-mail: lnkjc@126.com

http://www.lnkj.com.cn

Contents

目录

Introduction	简介	004
International Standards	国际标准	006
Terms	相关术语	007
Corner Lock Variations	角锁变化样式	008
Locking Methods	锁扣方式	010
Basic Structure	基本盒型	017
Designs	设计	
The Folding Carton	折叠纸盒	
Trays	盘式纸盒	024
Tubes	管式纸盒	146
Easels and Sleeves	支架和套盒	
Easels	支架	276
Sleeves	套盒	308
Corrugated Containers	瓦楞纸容器	
Corrugated Easels	瓦楞纸支架	332
Corrugated Boxes	瓦楞纸盒	368
Stands and Displays	展台和展示包装	
Stands	展台	404
Displays	展示包装	456

STRUCTURAL

包装

TB482.2
20161

DESIGN

结构

FOR

设计

PACKAGING

辽宁科学技术出版社

试读结束：需要全本请在线购买：www.ertongbook.com

图书在版编目 (C I P) 数据

包装结构设计 / 鞠海编. — 沈阳 : 辽宁科学技术出版社, 2016. 4

ISBN 978-7-5381-9596-5

I. ①包… II. ①鞠… III. ①包装容器—结构设计
IV. ①TB482. 2

中国版本图书馆 CIP 数据核字 (2016) 第 014392 号

出版发行: 辽宁科学技术出版社
(地址: 沈阳市和平区十一纬路 29 号 邮编: 110003)

印刷者: 辽宁新华印务有限公司

经销者: 各地新华书店

幅面尺寸: 215mm×280mm

印 张: 31.5

字 数: 50 千字

出版时间: 2016 年 4 月第 1 版

印刷时间: 2016 年 4 月第 1 次印刷

责任编辑: 殷文文

封面设计: 谭婷薇

版式设计: 鞠 海

责任校对: 周 文

书 号: ISBN 978-7-5381-9596-5

定 价: 198.00 元

联系电话: 024-23284360

邮购热线: 024-23284502

E-mail: lnkjc@126.com

http://www.lnkj.com.cn

Contents

目录

Introduction	简介	004
International Standards	国际标准	006
Terms	相关术语	007
Corner Lock Variations	角锁变化样式	008
Locking Methods	锁扣方式	010
Basic Structure	基本盒型	017
Designs	设计	
The Folding Carton	折叠纸盒	
Trays	盘式纸盒	024
Tubes	管式纸盒	146
Easels and Sleeves	支架和套盒	
Easels	支架	276
Sleeves	套盒	308
Corrugated Containers	瓦楞纸容器	
Corrugated Easels	瓦楞纸支架	332
Corrugated Boxes	瓦楞纸盒	368
Stands and Displays	展台和展示包装	
Stands	展台	404
Displays	展示包装	456

Introduction

简介

Along with the development of the products diversification, the packaging prototypes became to draw more and more attention of the consumers for the reason that the exquisite wrapped commodity could immediately attract people's eyes and thus seize the market in a short time. The packaging prototypes are undergoing constant change with the development of world economy and culture, however, the basic packaging structure from which they transformed is unaltered. This book represents the common packaging structures attached with the detailed plans and distinct 3-D modellings together with the highly pursued packaging prototypes in the current market. It gradually leads the readers to discover the package forming rules and the hidden rules that should be followed in the process of design.

Meanwhile, the book has also introduced a large number of single or locking structures as well as the classification criteria at the beginning of the book. It will surely serve as fulfilling resources for designers and common readers alike.

As an unprecedented collection of package prototypes, it could provide feasible packaging guidance and give designers more inspiration.

随着商品多样化的发展，商品的外包装也越来越引起消费者的重视，很多结构合理，外形美观的包装能一下吸引住消费者，迅速的抢占市场先机，达到事半功倍的功效。尽管商品的外包装样式不段的推陈出新，但包装物本身的结构都是由那些最基础的包装结构演化而来的。《包装结构》这本书系统的将包装结构分门别类，不但收录了最常见的包装结构，配以相关的平面图和包装成型后的外形图，同时也大量收录了现今最新颖的销售包装设计图，循序渐进的向读者展示包装物的成型规律和设计过程中应该遵循的潜在规则。

同时本书在前面用大量的篇幅介绍了大量的图例和包装物的单体结构、锁扣结构、包装的物的分类标准等。这些分类介绍和各种结构分类无论对包装结构设计师还是初入此行的同行都大有裨益。

本书既对传统结构进行了归类，又在这一基础上进行了适当的延展，使读者进一步掌握包装结构的演化规律，是一本功能性和参考性很强的参考书。

International standards 国际标准

A.L = Length of Box

A.L = 长度

B.W = Width of Box

B.W = 宽度

C.D = Depth of Box

C.D = 深度

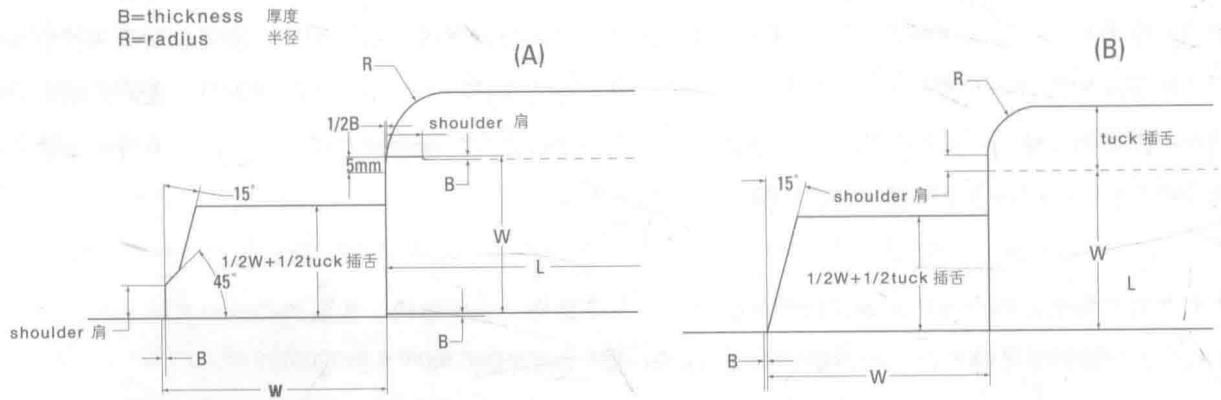

A		Generic Joint	一般折合线
B		Slide Fastener Cutting	拉链式齿刀线
C		Folding Machine Line	机折线
D		Glue Line	黏合线

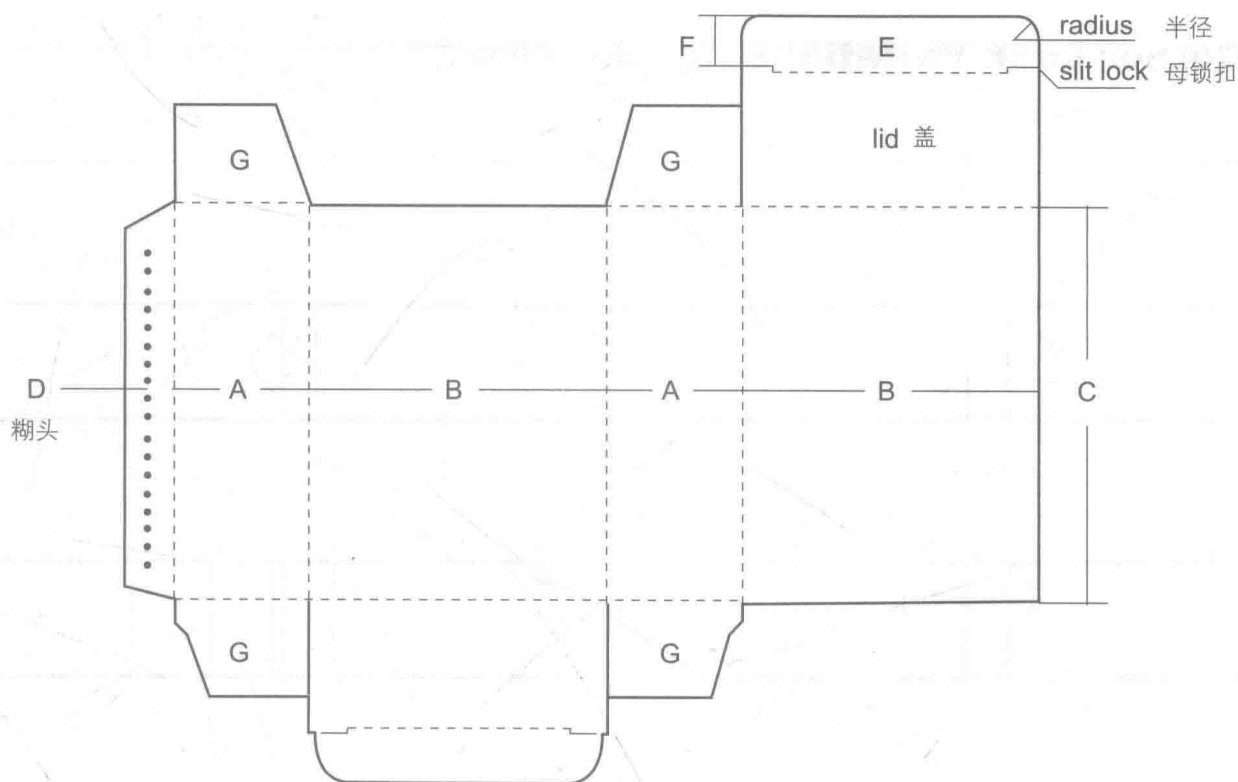

A.L=Length
B.W=Width
C.D=Depth
D.Glue Flap

E. Tuck
F. Shoulder
G. Dust Flap

A. L=长度
B. W=宽度
C. D=深度
D. 糊头
E. 插舌
F. 肩
G. 防尘翼

Terms 相关术语

R.T.E.
S.T.E.
French R.T.E.
Auto Bottom
123Bottom
Six/Four-points-glued Box

R.T.E.
S.T.E.
法国式 R.T.E.
自动底
123 底
六点/四点胶合盒

Reverse Tuck End
Straight Tuck End (For window box)
French Reverse Tuck End (For cosmeticss)
Auto Assemble
Snap Lock Bottom (For cosmeticsswine and food)
Beer Tray

反向插入式盒型
笔直插入式盒型
法国式反向插入盒型
自动组立成型的盒底
快速缩合底
在美国一般叫做啤酒托盘

Corner Lock Variations

角锁变化样式

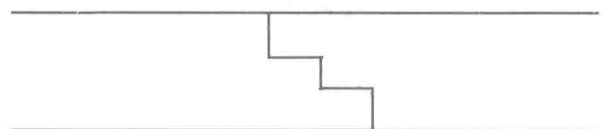
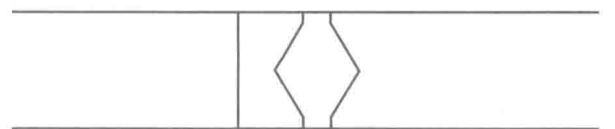
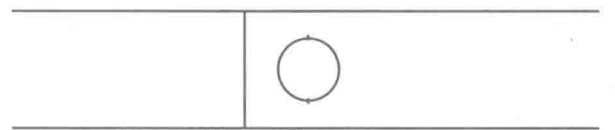
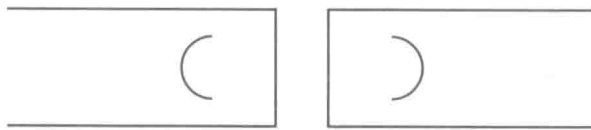
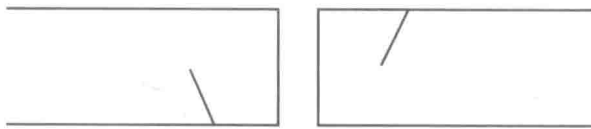
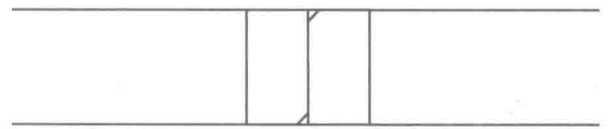
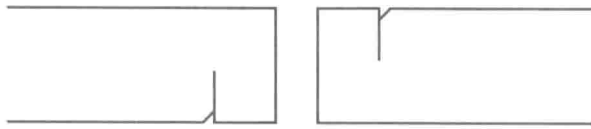
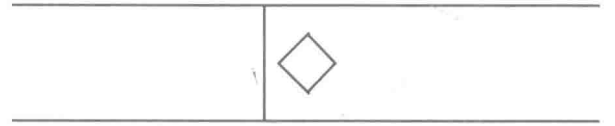
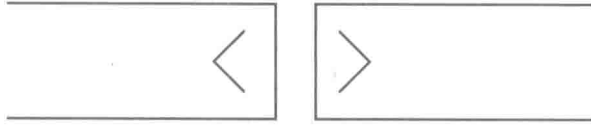

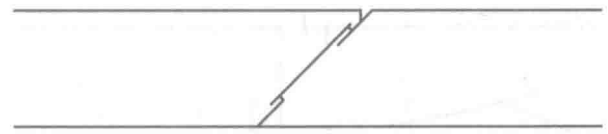
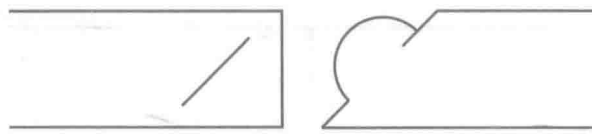
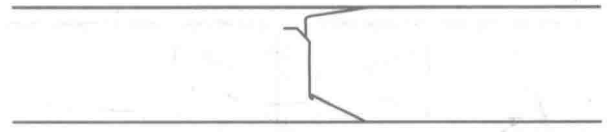
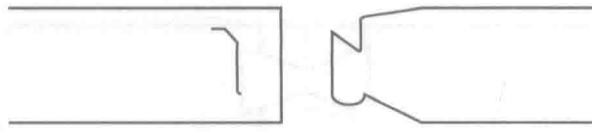
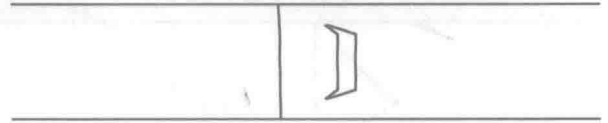
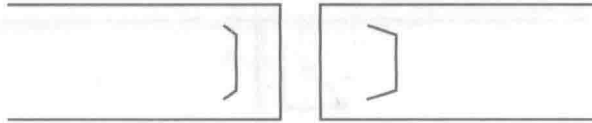
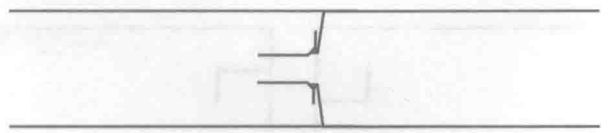
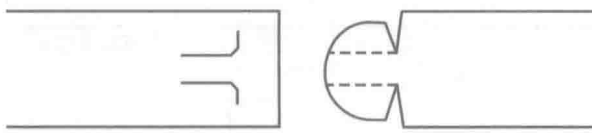

Locking Methods 锁扣方式

- | | |
|-----------------------------|----------|
| 1. Auto Locks | 1. 自动扣 |
| 2. Top panel Locks | 2. 顶锁 |
| 3. Side and End Panel Locks | 3. 边锁和底锁 |
| 4. Click Locks | 4. 快速锁 |
| 5. Foot Locks | 5. 脚扣 |
| 6. Double Locks | 6. 双扣 |
| 7. Gusseted Dust Locks | 7. 三角扣 |
| 8. Dust Flap Locks | 8. 防尘扣 |
| 9. Butterfly Locks | 9. 蝴蝶扣 |
| 10. Floral Locks | 10. 花扣 |

Auto Locks 自锁

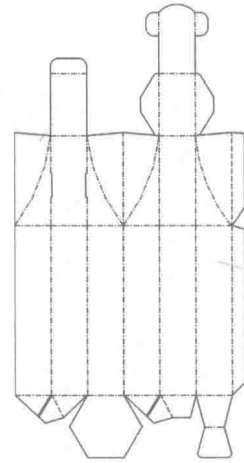
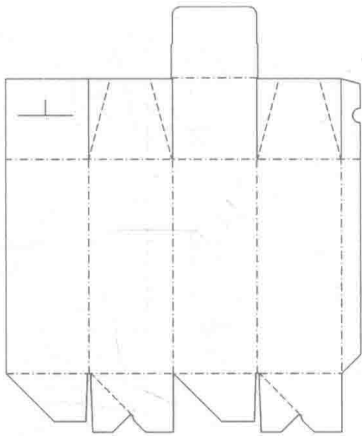
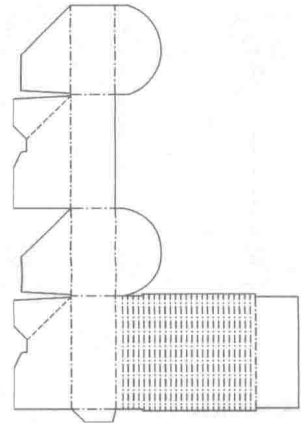
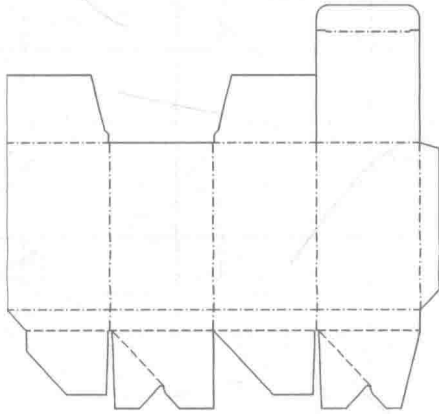

Top Panel Locks 顶锁

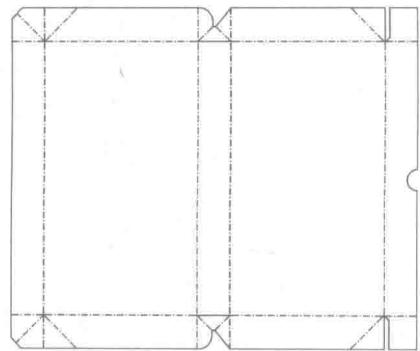
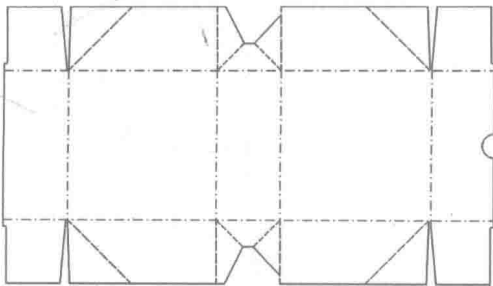

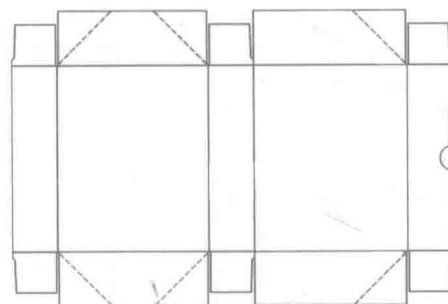
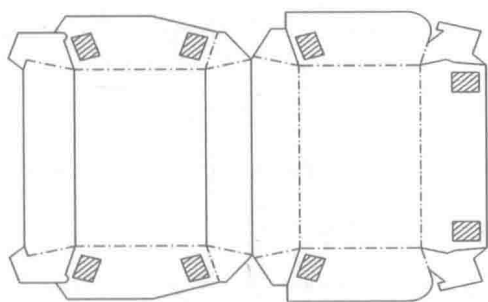

Auto Locks 自锁

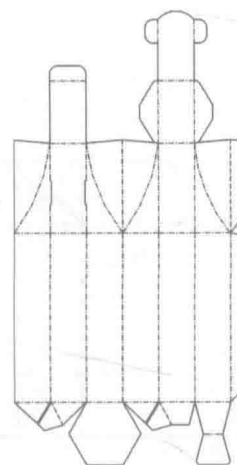
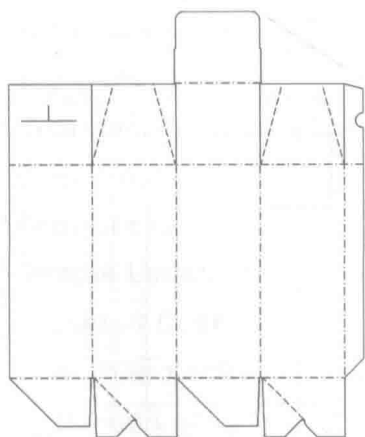
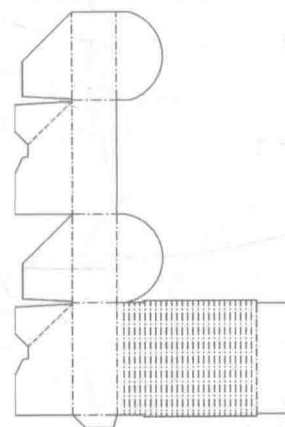
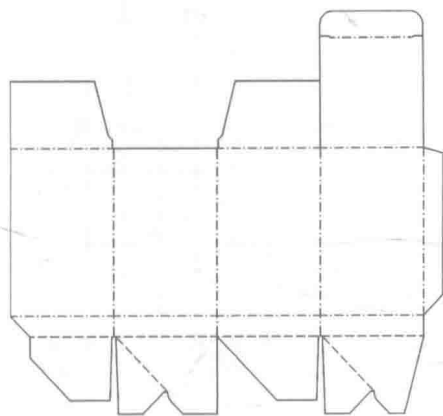

Top Panel Locks 顶锁

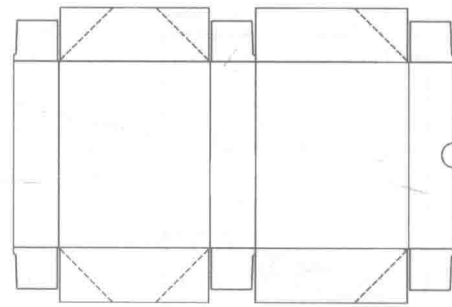
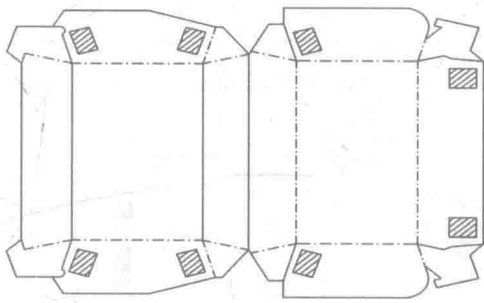
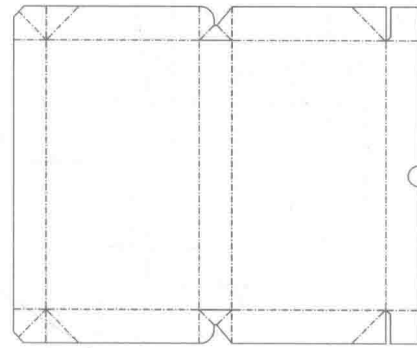
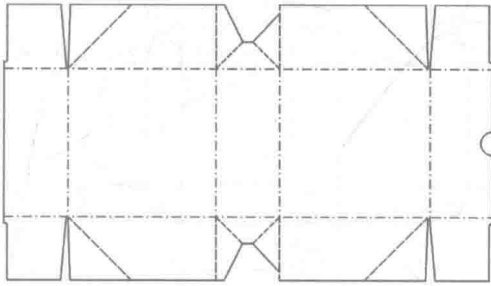

Foot Locks 脚锁

