

CREATIVE

DIAGRAM

IN

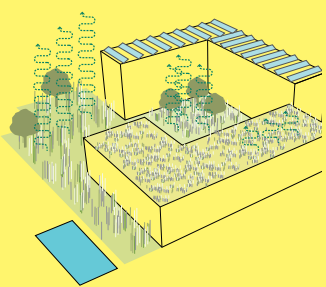

凤凰空间·北京 编

创意分析——

图解景观与规划

LANDSCAPE & PLANNING

江苏人民出版社



创意分析

——图解景观与规划

CREATIVE DIAGRAM IN
LANDSCAPE & PLANNING

凤凰空间·北京 编

江苏人民出版社

图书在版编目(CIP)数据

创意分析：图解景观与规划 / 凤凰空间·北京编.
— 南京：江苏人民出版社，2013.1
ISBN 978-7-214-08775-1

I. ①创… II. ①凤… III. ①景观规划—景观设计—
图集 IV. ①TU986.2-64

中国版本图书馆CIP数据核字(2012)第220251号

创意分析——图解景观与规划

凤凰空间·北京 编

策划编辑：胡中琦 曹 蕾
责任编辑：蒋卫国
特约编辑：曹 蕾
顾问编辑：徐馨莲
责任监印：彭李君
美术编辑：周 宇
出版发行：凤凰出版传媒集团
凤凰出版传媒股份有限公司
江苏人民出版社
天津凤凰空间文化传媒有限公司
销售电话：022-87893668
网 址：<http://www.ifengspace.cn>
集团地址：凤凰出版传媒集团（南京湖南路1号A楼 邮编：210009）
经 销：全国新华书店
印 刷：北京利丰雅高长城印刷有限公司
开 本：787 mm×996 mm 1/16
印 张：20
字 数：200千字
版 次：2013年1月第1版
印 次：2013年1月第1次印刷
书 号：ISBN 978-7-214-08775-1
定 价：278.00元（USD 50.00）

（本书若有印装质量问题，请向发行公司调换）



PREFACE 前言

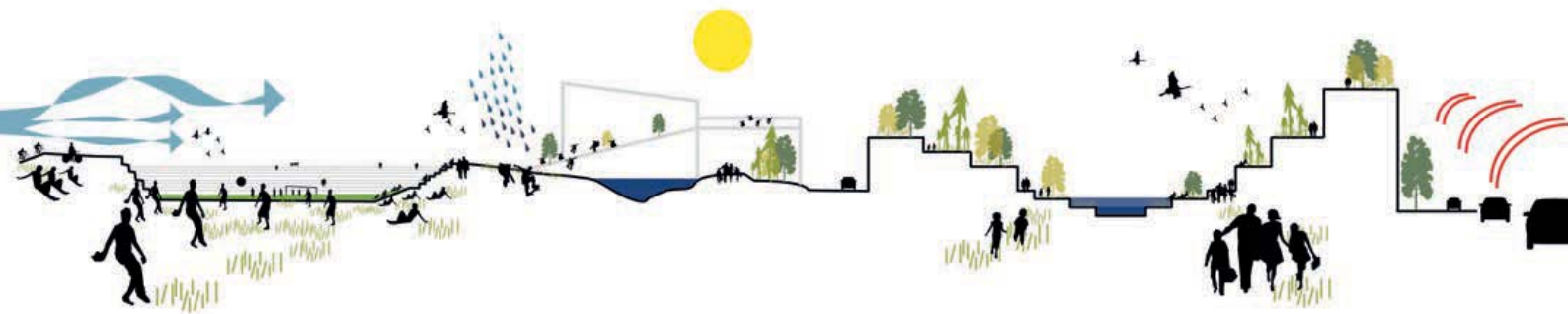

视觉是获取信息最直接的方式。身处读图时代，如何通过象征和抽象的图解语言形式来概括表达具体的或抽象的设计内容，方便人们直接观察和解读原本的设计内容，是设计师必须具备的能力。书中收录近百个国际、国内知名景观与规划设计公司的经典案例，它们使用恰当的表达元素、创新的表达方式，淋漓尽致地展现出设计意图与表达内容，是图解设计的典范之作。

设计的过程就是解决矛盾的过程，对问题的认识会影响到答案的形成。希望读者能通过本书掌握“运用图解简化矛盾、通过分析寻找答案”的方法，为设计插上灵感与创意的翅膀。

感谢北京主语空间文化发展有限公司邢丽丽对本书的帮助。

Vision is the most direct way to obtain information. In the era of "reading pictures", the designers must master the ability to convey the tangible or abstract design ideas through symbolized and metaphysical diagram language, so as to help other people better observe and analyze their designs directly. This book includes around one hundred classic projects from international landscape / planning design firms. These projects, as outstanding examples of diagram designs, manage to show the intention and content of the designs vividly and incisively through appropriate expression elements and creative expression styles.

The design process is the process of resolving problems, and the understanding of the problem will influence the answer. We hope this book can help the readers obtain a key design method, which is simplifying the problem with diagrams, and finding the answer through analyzing. It will give wings of inspiration and creativity to the design.

We extend sincere gratitude to Lily Xing from Beijing Urban Color Cultural Development Co., Ltd. for her great support to this book.



CONTENTS

目录

| 景观

景观元素 LANDSCAPE ELEMENT

008

- 010 MULTI MILL多功能舞台
MULTI MILL
- 011 篮球吧
BASKET BAR
- 012 空中连廊
SKY NETWORK
- 013 伯纳姆展亭
BURNHAM PAVILION
- 014 植物长椅
PHYTOBENCH
- 016 荷兰风车
WIND TURBINES IN THE DUTCH LANDSCAPE
- 018 乔丹住宅庭院景观
EXTENSION JORDAN
- 019 篱笆游泳池
LANDSCAPE FENCE
- 020 BAD室外浴室
BAD (BATH)
- 022 CROSS-WIND桥
CROSS-WIND BRIDGE
- 024 珠海十字门门户大桥
SHIZIMEN GATEWAY BRIDGE - THE INFINITY LOOP

- 026 瞭望塔
OBSERVATION TOWER
- 028 奥尔堡文化大桥
AALBORG CULTURAL BRIDGE
- 029 台湾塔
TAIWAN TOWER
- 032 纤维塔
MULTIPLE NATURES - FIBROUS TOWER

| 景观

公共空间景观 PUBLIC SPACE

036

- 038 科尔曼滑板公园
COLEMAN OVAL SKATE PARK
- 042 台中中央公园
TAICHUNG GATEWAY PARK
- 050 “震撼”公园
SENSATIONAL GARDEN
- 051 密斯·凡德罗广场
MIES VAN DER ROHE PLAZA
- 052 “绽放”——西雅图中心街区景观
THE BLOSSOMING OF SEATTLE CENTER
- 054 JÄRVAFÄLTET公墓
JÄRVAFÄLTET CEMETERY STOCKHOLM
- 058 六角公园
HEXAGONAL PARK
- 060 滑冰公园
ICE SKATING PARK

- 062 BAYWATCH公园
BAYWATCH
- 064 SUPERMARKET公园
PARK SUPERMARKET
- 068 客家文化主题公园
HAKKA CULTURAL PARK
- 070 STAR MAZE公园
STAR MAZE-EXTENSION PARK
GROOT VIJVERSBURG
- 072 23号公园
23PARK
- 076 BLEIZO绿色科技商务园
GREENTECH BUSINESS PARK BLEIZO
- 078 斯普利特RIVA海滨景观
RIVA SPLIT WATERFRONT
- 080 月亮公园
PARK OF LUNA
- 081 巴斯塔德景观规划
SEVEN STEPS FOR BÅSTAD
- 082 BAYRISCHER BAHNHOF景观规划
STADTRAUM BAYRISCHER BAHNHOF
- 086 京杭大运河生态景观规划
ECOSYSTEM THINKING MEETS 2000 YEARS
OF CIVILIZATION - CHINA GRAND CANAL STUDY
- 090 西班牙布尔戈斯景观规划
DOTS&LOOPS
- 094 DRECHTSTEDEN景观规划
KNOPEN VAN DE DRECHTSTEDEN

住区规划 RESIDENTIAL COMMUNITY PLANNING

098

- 100 STAIRSCRAPER住区设计
STAIRSCRAPER
- 102 空中花园住区设计
SKY-GARDEN HOUSES
- 104 MO-CO住区设计
MO-CO HOUSING
- 106 SGBC社区
SGBC COMUNITY
- 108 KOZIN社区
KOZIN NEIGHBOURHOOD
- 111 长沙ZED QUARTER社区规划
ZED QUARTE PROJECT, CHANGSHA
- 112 BLOEMKOOLOWIJKEN社区再生研究
REGENERATION STUDY ON BLOEMKOOLOWIJKEN
- 114 可持续社区
SUSTAINABLE NEIGHBORHOOD
- 118 雷根斯堡内城住宅区
INNERCITY RESIDENTIAL QUARTER
- 122 我们的社区
THIS IS MY STREET
- 126 HOMESTEAD多代同堂住宅区与幼儿园设计
HOMESTEAD MULTIGENERATIONAL HOUSING &
KINDERGARTEN

| 规划

城市规划与设计
URBAN PLANNING AND DESIGN

130

- 132 国家时尚创意中心总体规划
THE NATIONAL CREATIVE CLUSTER
- 138 新加坡科技设计大学总体规划
SINGAPORE UNIVERSITY OF TECHNOLOGY & DESIGN
- 142 THU THIEM新城规划
THU THIEM NEW URBAN AREA
- 148 DEL ISTMO大学新校区规划
UNIVERSIDAD DEL ISTMO
- 150 佛蒙特法学院总体规划
FRAMEWORK PLAN
- 152 黑色草甸
BLACK MEADOW
- 154 伦敦HACKNEY WICK区设计
HACKNEY WICK & FISH ISLAND
- 160 KLEINPOLDERPLEIN交叉路口区域设计
KLEINPOLDERPLEIN
- 162 WELLESLEY路和公园路的改造
REVITALIZATION WELLESLEY ROAD AND PARK LANE
- 164 柏林布赫园区规划
CAMPUS BERLIN-BUCH
- 168 希洪火车站区及总体规划
MASTERPLAN & STATION AREA, GIJÓN
- 170 巴绍里火车站区及总体规划
MASTERPLAN AND STATION AREA, BASAURI
- 178 索姆河码头
QUAIS DE LA SOMME
- 182 山水杭州
SHAN-SHUI HANGZHOU
- 184 博洛尼亚火车站区及总体规划
MASTERPLAN AND TRAIN STATION, BOLOGNA
- 185 欧登塞研究与知识园区
KNOWLEDGE AND RESEARCH PARK
- 192 北京妫河·建筑创意园区
BEIJING CREATIVE ZONE
- 196 波尔图港
PORTO OLIMPICO
- 200 FPM GAP 学院规划与设计
FPM GAP ACADEMY
- 204 东滩商务中心总体规划
TRANSIT ORIENTED CITY-DONGTAN CENTRAL BUSINESS MASTER PLAN
- 208 CDR-CDU总体规划
CDR-CDU
- 210 深圳雅宝高科技企业总部园
GALAXY YABAO HI-TECH ENTERPRISES HEADQUARTER
- 212 莫斯科绿河项目
GREEN RIVER PROJECT MOSCOW
- 214 维比-南奥胡斯复兴规划
VIBY - AARHUS SOUTH REGENERATION MASTERPLAN

- 
- 220 徐州铜山整体规划及建筑设计
**TONGSHAN MASTERPLAN AND
ARCHITECTURAL DESIGN, XUZHOU**
- 222 大连生态科技创新城概念规划
**CONCEPTUAL PLANNING OF DALIAN
ECOLOGICAL TECHNOLOGY INNOVATION CITY**
- 224 嘉士伯工业厂区改造规划与设计
VORESBY CARLSBERG
- 232 ILOT-FOLIEN城市规划与设计
ILOT-FOLIEN
- 236 BAGSVÆRD园区总体规划
BAGSVÆRD PARK MASTERPLAN
- 241 水平城市
HORIZONTAL CITY
- 244 TRÄDGÅRDAR区规划与设计
CONNECTED BLOCKS
- 246 山水葡萄酒庄园
SHAN SHUI GRAPE GARDEN
- 251 循环城市
LOOP CITY
- 254 OPPDAL规划与设计
OPPDAL PLUSS
- 256 威尼斯泻湖公园总体规划
**WEATHER VANE-VENICE LAGOON
PARK PLANNING**
- 260 天津生态城
TIANJIN ECO CITY
- 262 彼尔姆总体规划
PERM STRATEGIC MASTER PLAN
- 264 格罗宁根MEERSTAD总体规划
MASTER PLAN FOR GRONINGEN MEERSTAD
- 266 GROGUD中心规划与设计
CUMULUS
- 272 L.A.R.S.规划与设计项目
L.A.R.S.
- 276 混合谷物——KRÜCKAU-VORMSTEGEN城区规划与设计
MIXED GRAINS, KRÜCKAU-VORMSTEGEN
- 280 马格德堡科技港
MAGDEBURG SCIENCE HARBOUR
- 284 汉堡IBA实验室港口新城
**HAFENCITY HAMBURG IBA
LABORATORY COASTAL TOWN**
- 290 XERITOWN迪拜生态城镇规划
XERITOWN
- 294 2050超冲积平原
2050 ULTRA FLOOD PLAIN
- 302 RØDOVRE SYD城市规划与设计
URBAN PLAN RØDOVRE SYD
- 304 埃斯林根城西新区规划
NEW CITY WEST
- 308 布鲁塞尔MACHELEN-DIEGEM区规划
MACHELEN-DIEGEM
- 314 城市缝合器——佛山东平新城城市设计
**URBAN ZIPPER - FOSHAN DONGPING
NEWTOWN URBAN DESIGN**

LANDSCAPE ELEMENTS

CREATIVE DIAGRAM IN LANDSCAPE & PLANNING

景观 |

景观元素

008—035

SCAPE ENT



扫描查看本章项目详细信息

MULTI MILL多功能舞台

MULTI MILL

设计公司 / NL Architects
地点 / 荷兰, 阿姆斯特丹

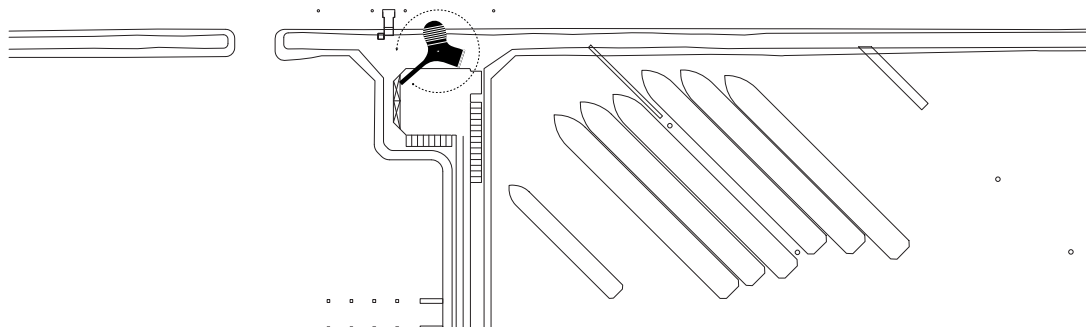
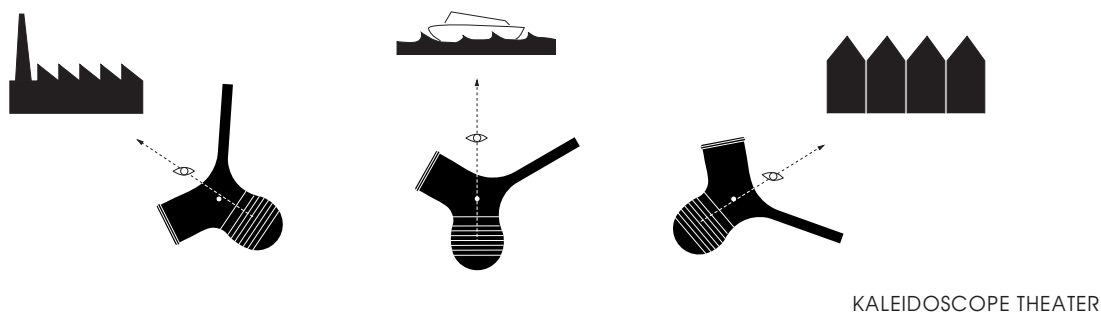
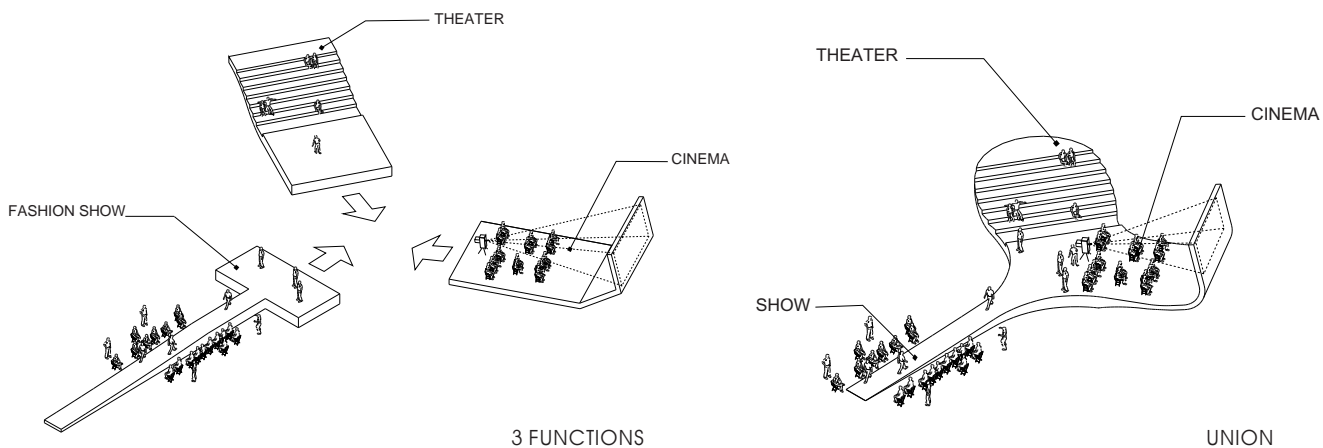

篮球吧 BASKET BAR

设计公司 / NL Architects
地点 / 荷兰, 乌得勒支

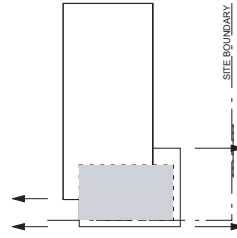

1. EXISTING BOOKSTORE

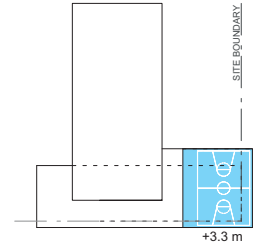

2. BASKETBALL COURT

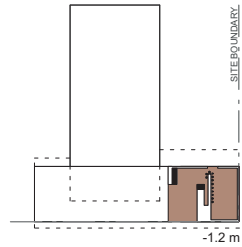

3. 255 m² SUNKEN CAFE: THE CONVERSATION PIT

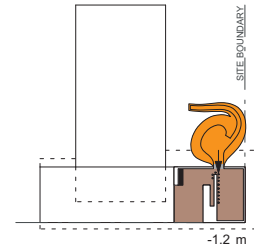

4. SUNKEN TERRACE + ENTRANCE FOR THE DISABLED ON THE SAME LEVEL WITH CAFE = SKATEBOWL

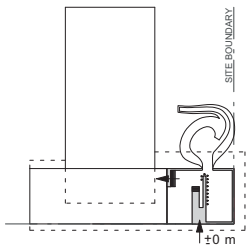

5. THE CATWALK: ENTRANCE ON TOP OF THE BAR.
+ CONNECTION TO THE BOOK STORE
+ NEW STORE

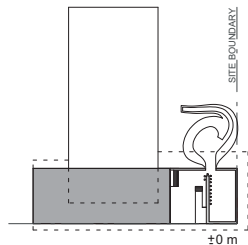

6. BAR BEP BAR (WHO'S BEHIND THE BAR?)
+ 60 m² BAR ENVELOPING THE CAFE
+ NEW BOOK STORE

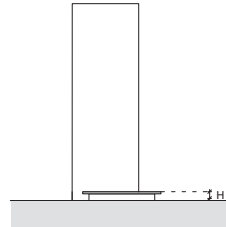

1. $H = 2.60\text{ m}$
THE EXISTING BOOKSTORE WITH A FLAT ROOF: IT'S BEAUTIFUL

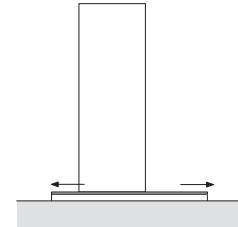

2. $H = 2.60\text{ m}$
THE NEW CAFE + BOOKSTORE EXTENSION: MORE FLAT = MORE BEAUTIFUL

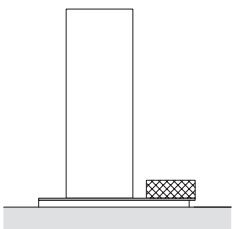

3. $H = 2.60\text{ m}$
THE ROOF BECOMES BIG ENOUGH TO FIT A BASKET COURT ON TOP.

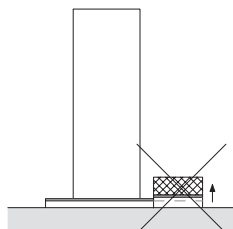

4. $H = 3.80\text{ m}$
THE CAFE NEEDS SUFFICIENT CLEARANCE TO BECOME "GRAND", BUT A BROKEN ROOF FRUSTRATES ELEGANT FLATNESS.

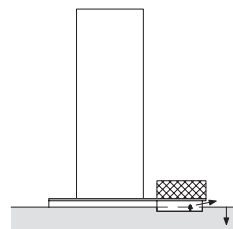

5. $H = 3.80\text{ m}$ THE ROOF REMAINS FLAT. THE BAR FLOOR SINKS IN THE GROUND: INTIMACY COMBINED WITH AN EXTENSIVE VIEW. THE DEPT OF THE SUNKEN CAFE EQUALS THE HEIGHT OF A REGULAR BAR: YOU ENTER ON TOP OF THE COUNTER. BAR = CATWALK!

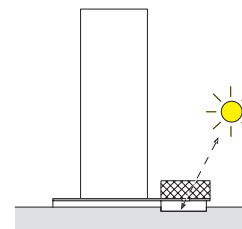

6. $H = 3.80\text{ m}$ THE TRANSPARENT MIDDLE CIRCLE PROVIDES A VISUAL CONNECTION BETWEEN BASKET AND BAR AND ALLOWS NATURAL LIGHT TO PENETRATE INTO THE HEART OF THE CAFE.

空中连廊 SKY NETWORK

设计公司 / Tiago Barros
地点 / 美国, 纽约

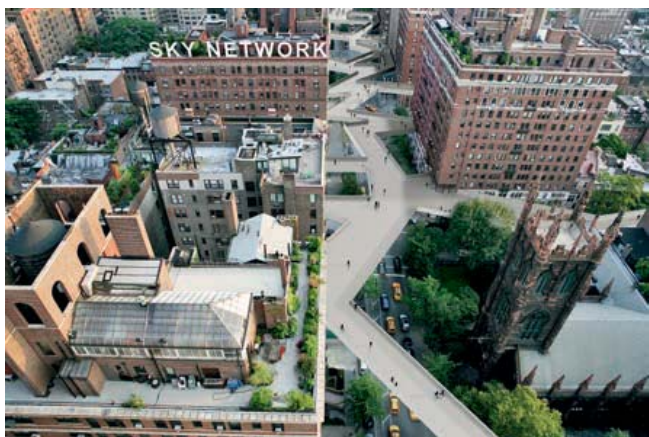

AERIAL VIEW



ENDLESS VIEW

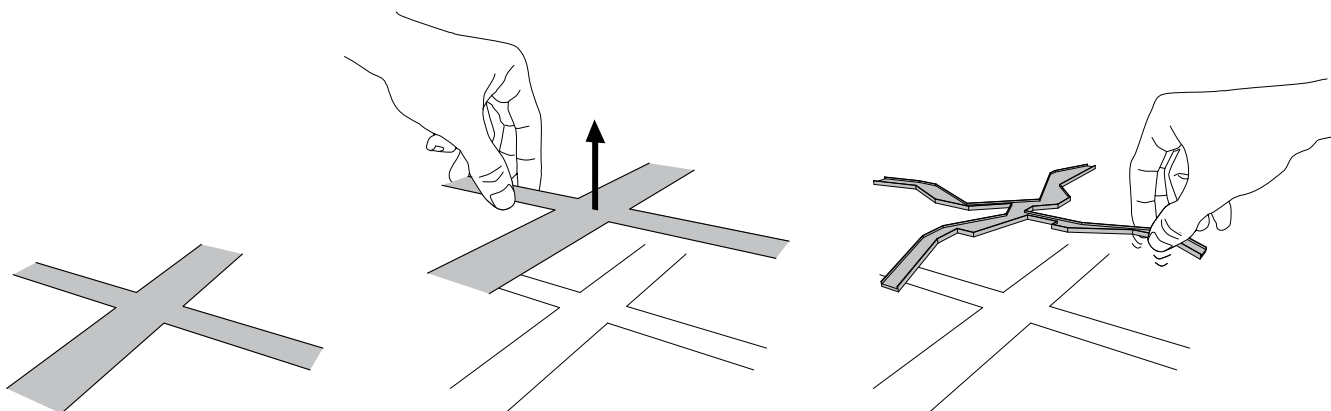

CONCEPT DIAGRAM

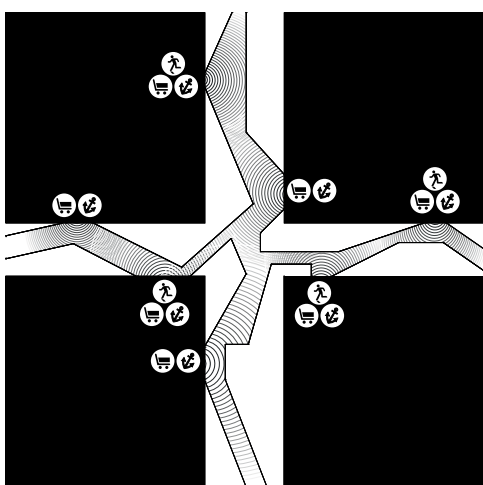

PLAN

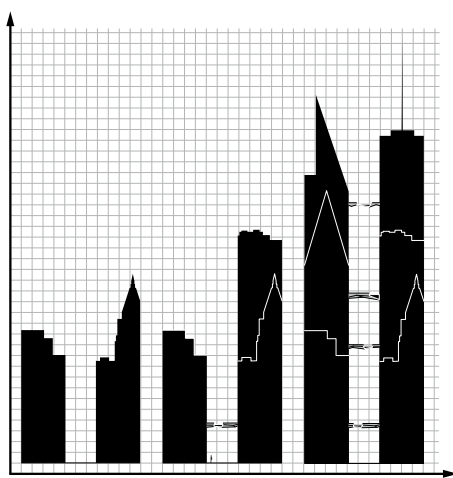

FUTURE DIAGRAM

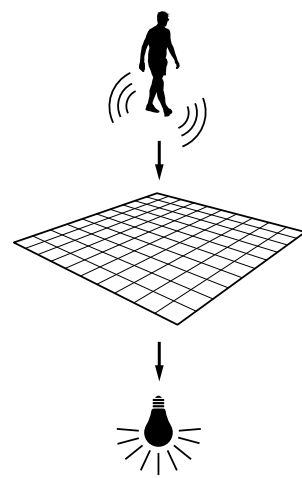

"MOTION SENSORS TO LIGHTING" DIAGRAM

伯纳姆展亭

BURNHAM PAVILION

设计公司 / UNStudio
地点 / 美国, 芝加哥



Views and Orientation

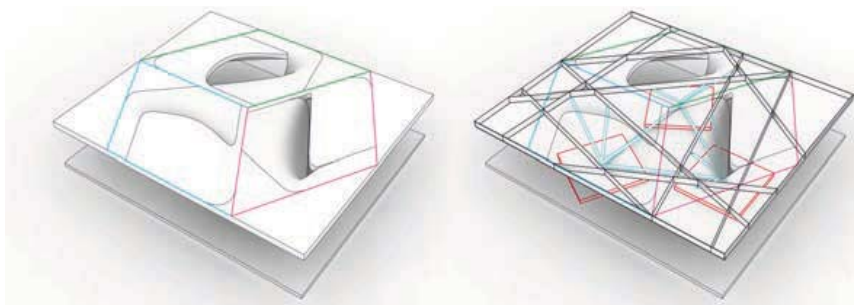
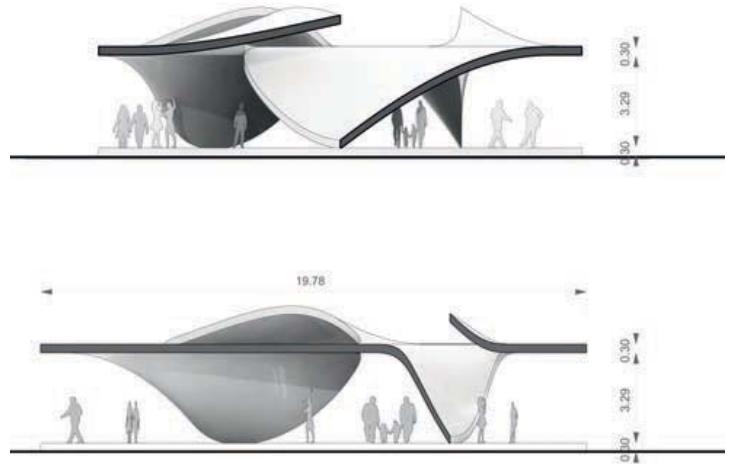
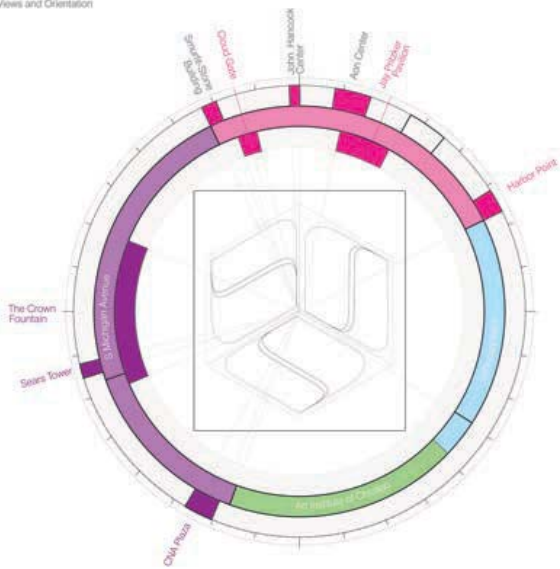

植物长椅 PHYTOBENCH

设计公司 / E/B OFFICE
地点 / 美国, 纽约

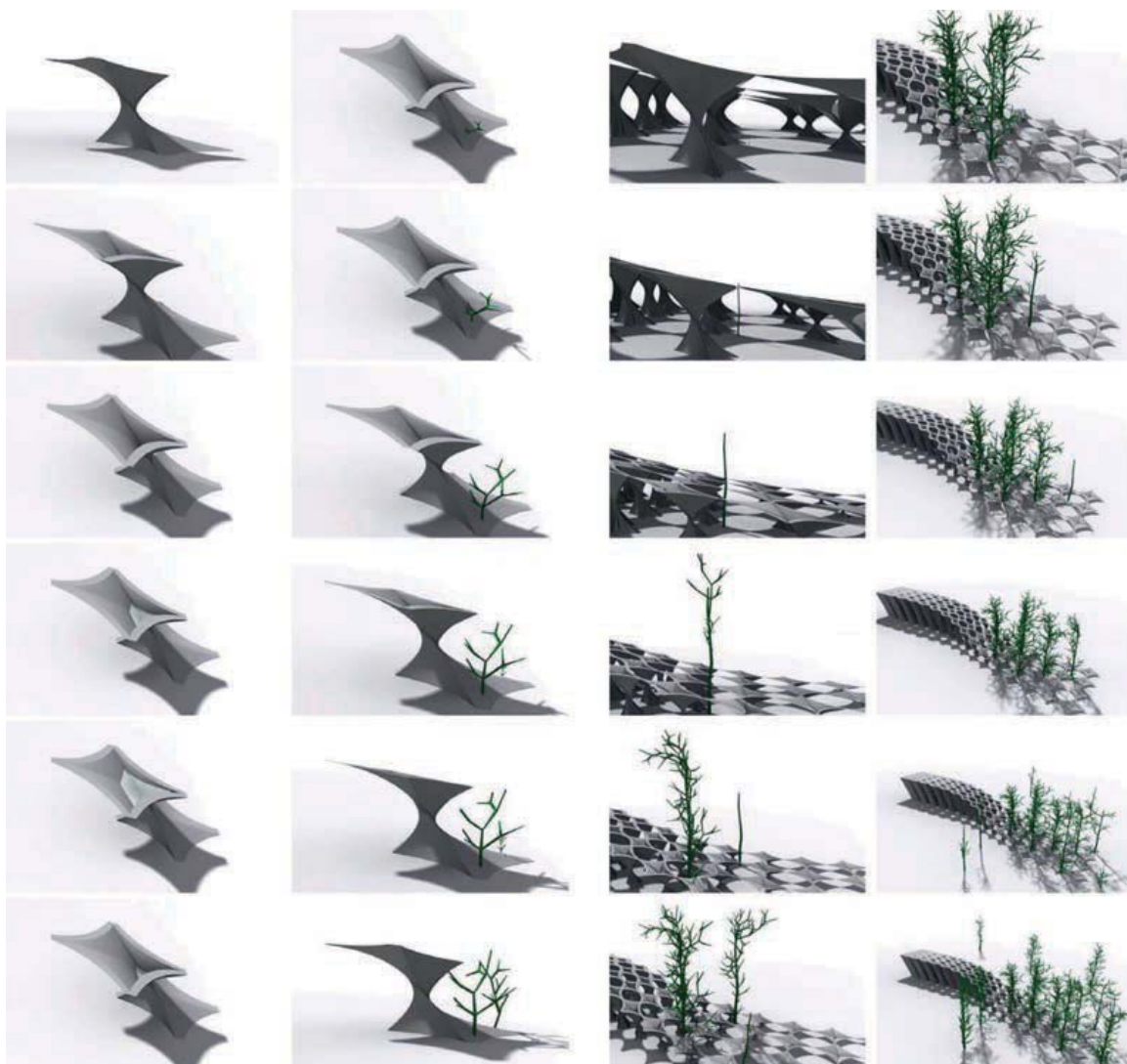
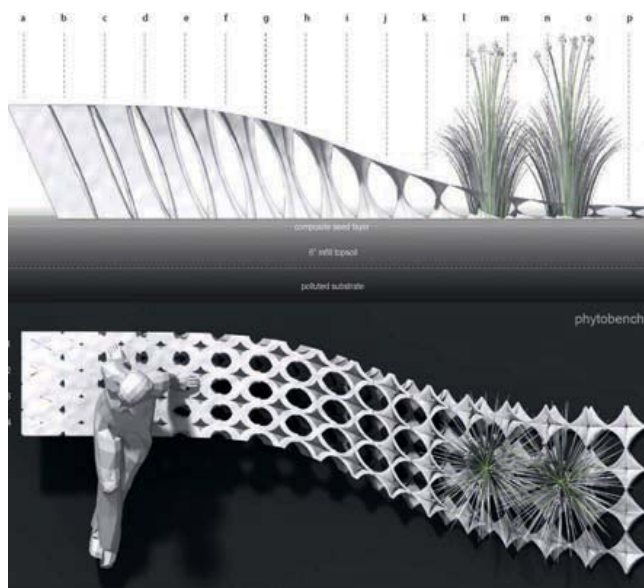

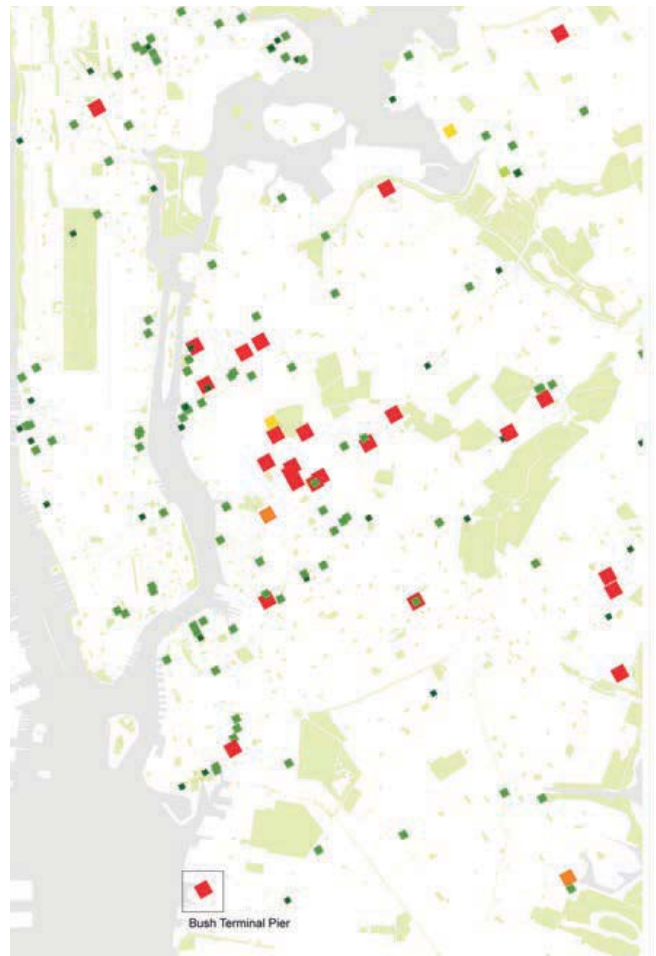
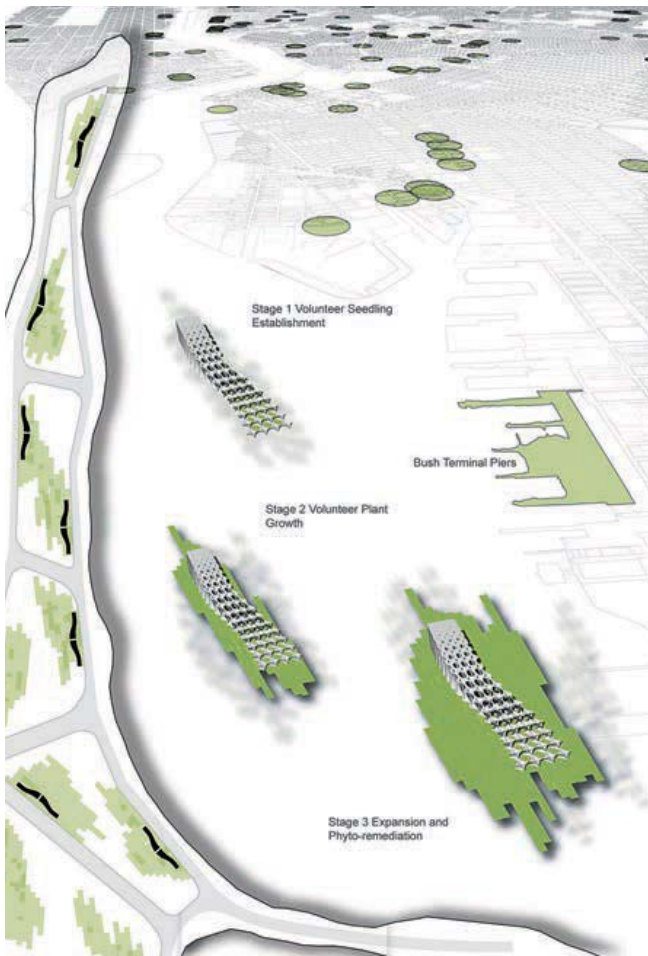

- Class 2** - The disposal of hazardous waste has been confirmed and the presence of such hazardous waste or its components or breakdown products represent a significant threat to the environment or to health.
- Class 3** - Contamination does not presently constitute a significant threat to public health or the environment.
- Class 4** - Site has been properly closed but that requires continued site management, consisting of operation maintenance, and monitoring.
- Class 5** - Site has been properly closed in a setting where a consequential amount of hazardous waste or its constituents remain, but do not require continued operation, maintenance and/or monitoring.
- Class A** - Non-registry site in any remedial program where work is underway and not yet complete.
- Class C** - sites where the Department has determined that remediation has been satisfactorily completed.

Source: New York State Department of Environmental Conservation

荷兰风车

WIND TURBINES IN THE DUTCH LANDSCAPE

设计公司 / NL Architects
地点 / 荷兰

